

F²MC-8FX Family

FRAM Microcontroller Series

MB95R203

FRAM microcontroller is a next-generation device with the features of both ROM and RAM that can realize high-speed programming and low power consumption. Mass production of MB95R203 will be started in April 2009. It is optimal for log data acquisition at low voltage detection and applications to back up data in digital devices.

Introduction

“FRAM microcontroller series” with built-in nonvolatile memory “FRAM (Ferroelectric Random Access Memory)” has been added to the standard commercial product lineup of the 8-bit microcontroller 8FX family. FRAM microcontrollers are next-generation devices that have the features of both ROM and RAM and that realize high-speed programming and low power consumption. FUJITSU will start the mass production of our FRAM microcontroller series “MB95R203” in April 2009, ahead of our competitors.

This product is optimal for the acquisition of log data at low voltage detection and applications to back up data in digital devices.

Advantages of FRAM Microcontrollers

FRAM microcontroller series “MB95R203” adopts the nonvolatile memory “FRAM” for its built-in memory. FRAM microcontrollers have the following advantages compared to Flash microcontrollers:

■ Data maintenance even when the power is cut off

Since FRAM is a nonvolatile memory, data is maintained even when the power is cut off. Furthermore, FRAM has “high-speed

programming in units of bytes” and “no special command required for erasing/writing” features. These allow FRAM microcontrollers to rewrite data instantaneously even when the power is cut off unexpectedly.

For example, a Flash microcontroller requires a more than 25 times longer write period than a FRAM microcontroller under the same access speed and memory density conditions. In addition, data erase time must also be considered for Flash microcontrollers since they are not capable of data rewriting.

Figure 1 presents a comparison of write time between a FRAM microcontroller and a Flash microcontroller.

This product is also equipped with a FRAM power supply monitor; write/read operation on FRAM is stopped until the

Photo 1 External View (SOP-20)



Figure 1 Comparison of Write Time between FRAM Microcontroller and Flash Microcontroller

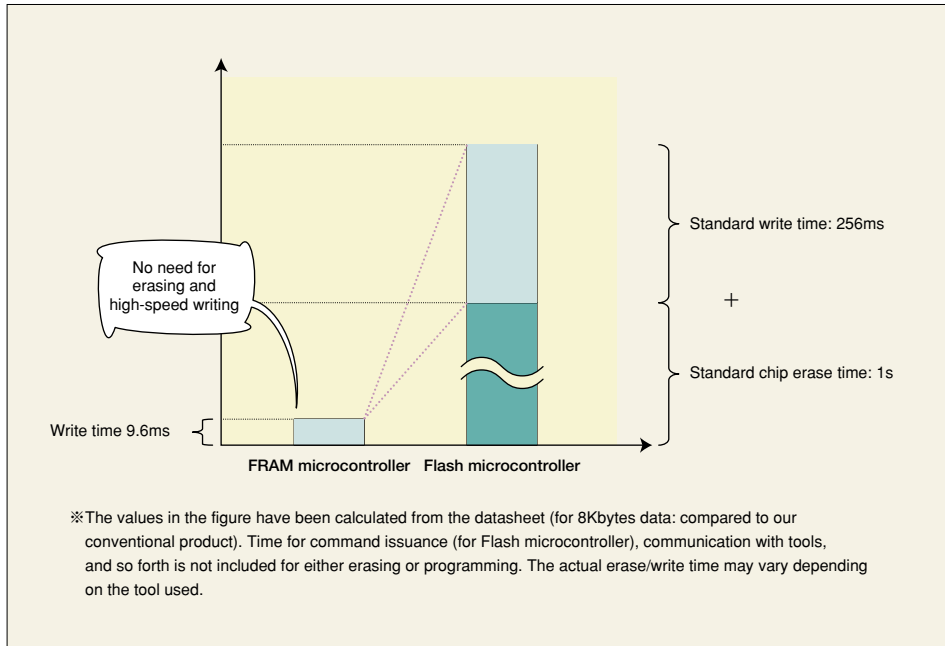
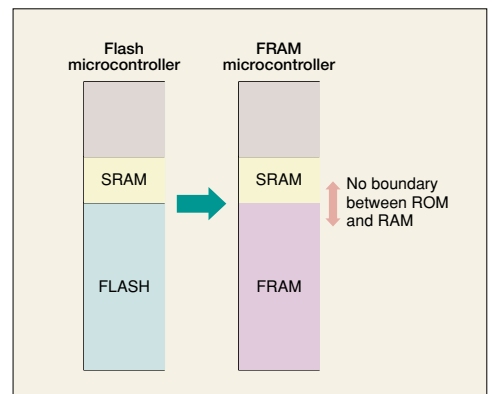

Figure 2 Memory Map Image for FRAM Microcontroller/Flash Microcontroller



power voltage is restored when voltage drop is detected by the monitor. Thus, this function to monitor FRAM power supply protects the FRAM data.

Both program and data can be assigned in FRAM area

FRAM area can be used as either ROM or RAM area. The ROM/RAM range can be specified by the user and protection to prevent rewriting can be provided on areas where rewrite is not desired (program area). Conversely, the area the user wishes to rewrite can be rewritten randomly in units of bytes.

Figure 2 presents the memory map image for a FRAM microcontroller and a Flash microcontroller.

This product also has a built-in FRAM security function to prevent unauthorized reading.

FRAM microcontrollers are friendly to the global environment

FRAM microcontrollers offer low power consumption. Compared to a Flash microcontroller with the same density, a FRAM microcontroller can reduce the operation power under normal operation (reading operation) by approximately 30%.

Furthermore, Flash microcontrollers require approximately 2.5-fold the operation power in writing than in normal operation mode because they require high

Figure 3 Block Diagram

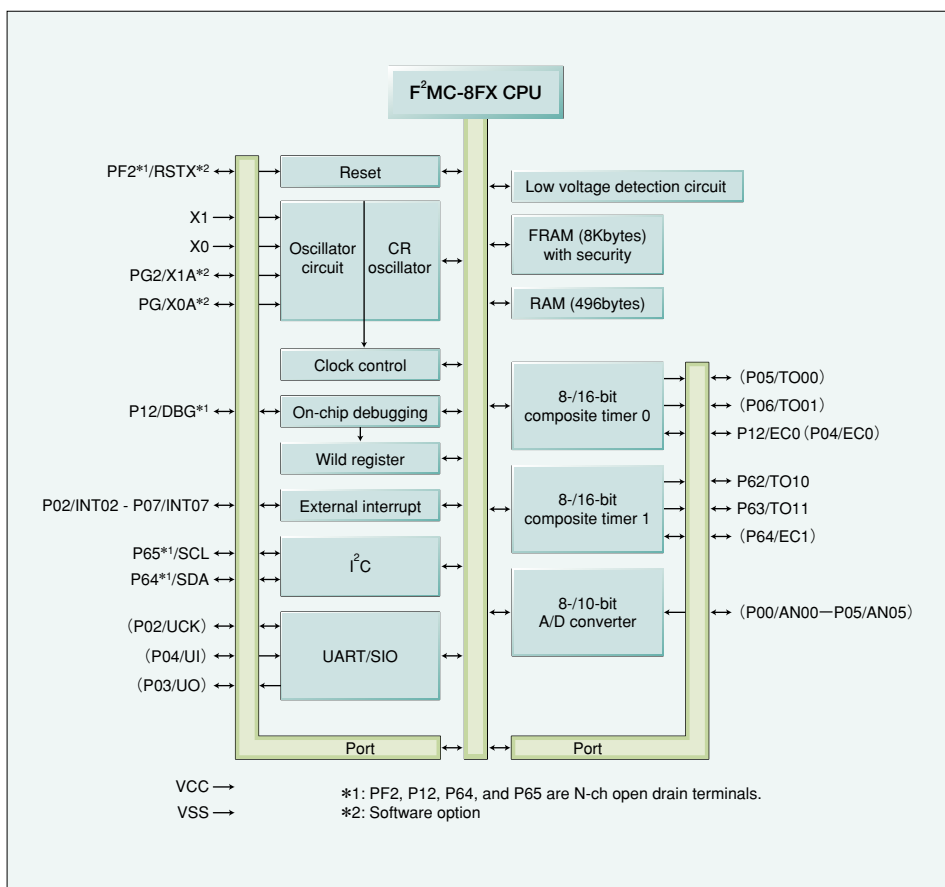
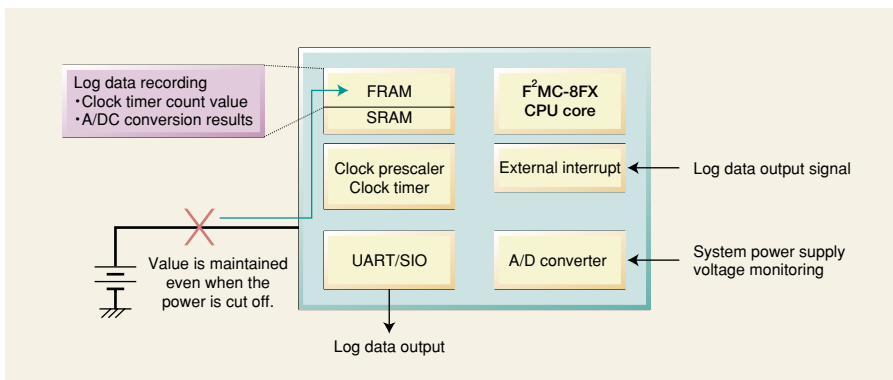

Table 1 List of Functions

FRAM	8Kbytes (program area/data area)
RAM	496bytes
CPU	F ² MC-8FX
Built-in CR oscillation	Main CR clock 1MHz/sub-CR clock 100kHz (standard)
Low power consumption mode	Sleep mode, stop mode, clock mode (when sub-clock is used), time-based timer mode
Undervoltage detection circuit	Undervoltage detection reset function, FRAM power supply monitoring function
I/O port	16
	CMOS: 12, N-channel open drain: 4
Watchdog timer	Total of 2 channels for hardware and software
UART/SIO	1 channel
A/D converter	6 channel
	Selectable between 8-bit/10-bit resolutions
Composite timer	8-bit×2 channels, or 16-bit×1 channel
	Interval timer function, PWC function, PWM function, input capture function
External interrupt	6 channel
Clock supervisor	Equipped
On-chip debugger (OCD)	Single-line serial control, serial writing supported (CLK asynchronous)
Security function	FRAM security equipped (unauthorized reading prevented)
Operation voltage	3.0 to 3.6V (under normal operation)
	3.0 to 3.6V (in OCD mode)
	2.6 to 3.6 (in STOP mode)
Guaranteed operation temperature range	−20 to +70°C (under normal operation)
	+5 to +35°C (in OCD mode)
Package	SDIP-24, SOP-20

Figure 4 Application Examples

voltage application during erasing and programming the Flash memory. FRAM microcontrollers do not require high voltage and thus cause no change in power consumption in writing operation.

Functions

Table 1 presents the list of functions for this product and **Figure 3** its block diagram.

The product has general built-in peripheral functions such as external interrupt, timers, I²C, and A/D converter.

Application Examples

FRAM microcontrollers are optimal as an alternative system to low voltage detection devices. Data can be directly written into the built-in FRAM using CPU commands. For example, it is possible to detect the power supply fluctuation on the system at the A/D converter and to store the error directly in FRAM.

Figure 4 presents some application examples. This product can be used to realize the following systems:

- ① Storage of conversion results by A/D converter in FRAM at clock timer interrupt timing
- ② FRAM value is maintained even when the system power is cut off.
With FRAM, there is no need to worry about power supply cutoff during erasing as in Flash memories. Programming is carried out at high speed compared to Flash memories since FRAM requires no erase/write commands and is capable of data rewriting.
- ③ Log data is output via serial communication to respond to the request signal by external interrupt after power restoration.

Development Environment

Table 2 presents the list of development environments and **Figure 5** the development environment configuration.

The emulator for debugging is also equipped with a FRAM writer function, and allows construction of a compact development environment. The development environment can be commonly used for the F²MC-8FX family's low-pin count

First exhibition in Embedded Technology 2008 FRAM microcontrollers have got favorable reviews from visitors.

(* Exhibition period: November 19 to 21, 2008, Pacifico Yokohama)



ET2008 FRAM microcontroller exhibit

Reversi game (left side of the above photo) and counter demonstration (right side of the photo) were exhibited at our FRAM microcontroller booth.

FRAM microcontrollers capable of high-speed programming can record data instantaneously

even when unexpected system power cutoff occurs. This product maintains data before power cutoff when the power is restored.

The built-in FRAM on microcontroller securely records the game progress status in the Reversi game and the count value in the counter.