

# MB86H60

## Multi Standard Decoder for Set-Top-Boxes

### Introduction

This Fujitsu MB86H60 is a highly integrated System-on-Chip (SoC) and complies with the DVB standard currently used in various regions, mainly Europe. The LSI decodes full HD (1920dots x 1080lines) video compressed in either MPEG-2 or H.264 and integrates on a single chip the necessary processing functions for a HD broadcast receiver, including processing of digital video, audio, and graphics. This makes the multi-decoder product suitable for TVs, STB, and portable TV receivers. Also, as the LSI's functions can be implemented with the addition of only two 16-bit wide external memory chips, it allows set vendors to reduce their total costs when designing their TVs and set-top-boxes.

The TV or display can be connected in HD resolution analog via component output or digital via copy protected HDMI interface (Link and PHY). A down-sampled SD format can be provided in parallel.

The MB86H60 device supports multiword DMA for ATA devices. Embedded USB 2.0 High Speed OTG Link and 10/100 Base-T Ethernet MAC are provided for connectivity.

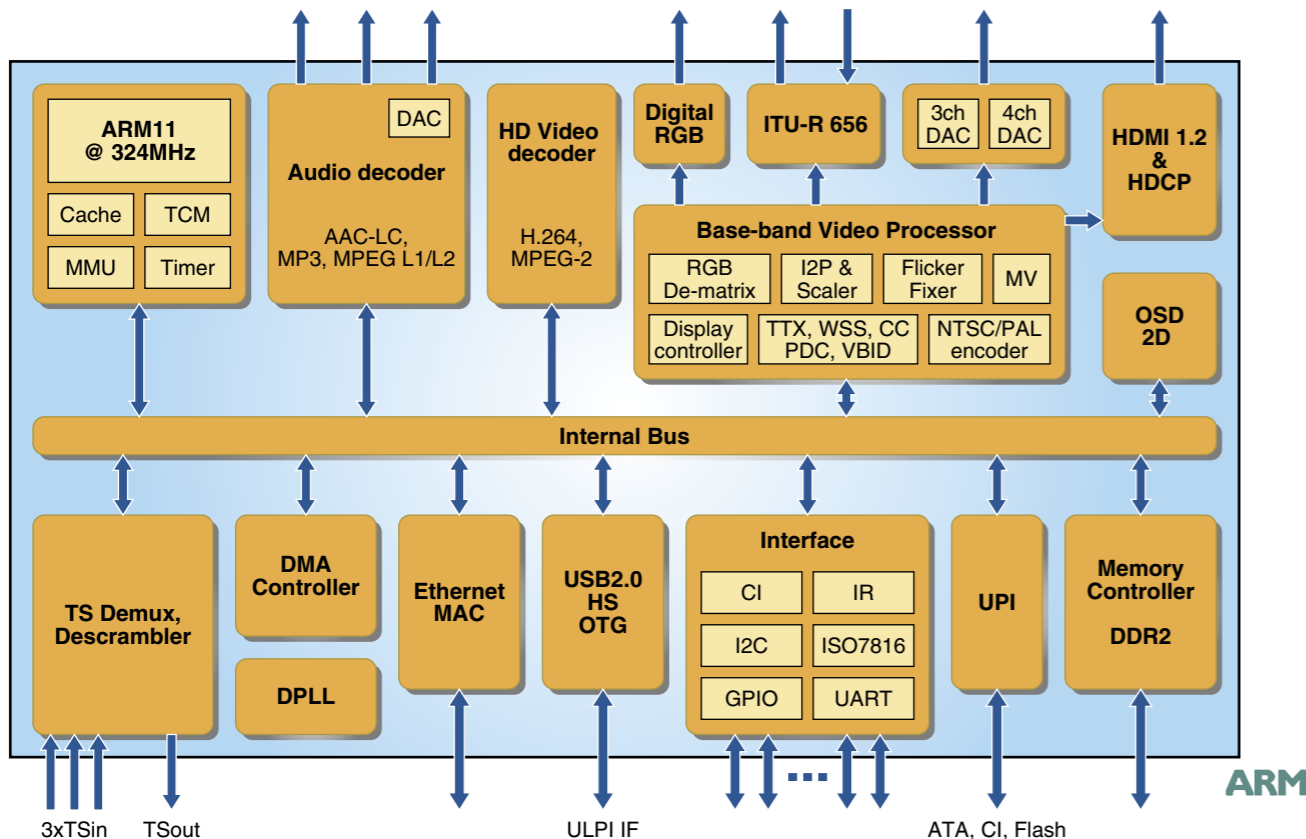

### Features

- Decodes both full HD MPEG-2 and H.264, supporting current and next-generation European broadcasting standards. This multi-decoder LSI can be used for current standard-definition MPEG-2 broadcasts used widely in Europe and other regions, and for next-generation HD broadcasts using H.264.
- Integrates on a single chip all functions necessary for HD TV processing. The CPU core in the LSI is the high-performance ARM1176JZF-S™, which supports a wide range of functions including system control for TVs and set-top boxes, teletext, subtitles, and JPEG decoding. In addition, by integrating audio, graphic video processing, and functions required for processing HD broadcasts on one chip, Fujitsu's full HD multi-decoder LSI enables set vendors to more easily construct their systems.
- Complete Functionality by Adding Two 16-bit wide DDR2-SDRAMs. By simply connecting two 16-bit wide DDR2 SDRAM667 external memory chips as working memory to the multi-decoder chip, the chip becomes fully functional, including CPU-based system control and digital-video decoding. This allows set vendors to reduce the total cost of their systems.
- Four video-transfer ports for connectivity to various devices. With four video-transfer ports, this multi-decoder LSI can be connected to a wide variety of external devices. For example, the LSI makes it possible to connect to digital video recorders (DVRs) which record TV broadcasts to a hard disk drive, or to connect to a conditional access card to view restricted digital broadcasts.

### Specifications

<b>CPU core</b>	ARM1176JZF-S™ *1 CPU @ 324MHz	
<b>Video</b>	Spec	H.264 High profile / Level 4.0 Decoder, MPEG-2 Video Main profile / High Level Decoder
	Resolution	1920 x 1080 x 60i/50i, 1440 x 1080 x 60i/50i, 1280 x 720 x 60p/50p, 720 x 480 x 60i, 720 x 576 x 50i
	Video encoder	Supports PAL/NTSC/SECAM, 7ch Video DAC embedded, Supports Teletext/WSS/PDC/CC/VBID
	Interface	ITU-R 656 I/O, digital RGB888 output, YPrPb analog HD output
<b>Audio</b>	Format	MPEG-1/2 Layer I/II/III, MPEG-2/4 AAC LC, etc
	Channels	5.1channels
	Interface	L/R serial, S/P-DIF
<b>TS processing</b>	Format	MPEG-2 TS standard
	Interface	3 output streams, 1 input stream, Built-in DVB descrambler
	Encryption processing	3DES encryption/decryption
<b>DDR2 memory interface</b>	2 x 16-bit width DDR2-SDRAM667, Supports 256Mbit to 1Gbit SDRAM	
<b>Flash memory interface</b>	Supports serial flash, NOR flash, NAND flash	
<b>Display</b>	5 planes: background (BG), video, cursor, OSD x 2	
<b>USB</b>	USB 2.0 high-speed OTG controller	
<b>Ethernet</b>	10/100baseT MAC	
<b>ATA</b>	Multiword DMA ATA interface (16Mbps)	
<b>HDMI</b>	HDMI 1.2 Link and PHY with HDCP 1.1	
<b>UPI</b>	NAND/NOR flash, common interface	
<b>Peripherals</b>	UART x 2, Smart card, I <sup>2</sup> C x 2, GPIO, PWM, IR Rx/Tx, SPI output	
<b>Input clock frequency</b>	27MHz	
<b>Operating clock frequency</b>	Internal: 324MHz, DDR2 memory interface: 324MHz	
<b>Power consumption</b>	1.2W (typ.)	
<b>Packaging</b>	484-pin PBGA, 27sq.mm (1.0-mm pitch)	

\*1 ARM1176JZF-S is the trademark of ARM Limited.

### FUJITSU MICROELECTRONICS LIMITED

Shinjuku Dai-ichi Seimei Bldg. 7-1, Nishishinjuku 2-chome, Shinjuku-ku, Tokyo 163-0722, Japan Tel: +81-3-5322-3347 Fax: +81-3-5322-3387 <http://jp.fujitsu.com/fml/en/>

**North and South America**  
FUJITSU MICROELECTRONICS AMERICA, INC.  
1250 E. Arques Avenue, M/S 333  
Sunnyvale, CA 94085-5401, U.S.A.  
Tel: +1-408-737-5600 Fax: +1-408-737-5999  
<http://www.fma.fujitsu.com/>

**Europe**  
FUJITSU MICROELECTRONICS EUROPE GmbH  
Pittlerstrasse 47, 63225 Langen,  
Germany  
Tel: +49-6103-690-0 Fax: +49-6103-690-122  
<http://emea.fujitsu.com/microelectronics/>

**Korea**  
FUJITSU MICROELECTRONICS KOREA LTD.  
206 KOSMO TOWER, 1002 Daechi-Dong,  
Kangnam-Gu, Seoul 135-280 Korea  
Tel: +82-2-3484-7100 Fax: +82-2-3484-7111  
<http://www.fmk.fujitsu.com/>

**Asia Pacific**  
FUJITSU MICROELECTRONICS ASIA PTE LTD.  
151 Lorong Chuan, #05-08 New Tech Park  
Singapore 556741  
Tel: +65-6281-0770 Fax: +65-6281-0220  
<http://www.fujitsu.com/sg/services/micro/semiconductor/>

**FUJITSU MICROELECTRONICS SHANGHAI CO., LTD.**  
Rm. 3102, Bund Center, No.222 Yan An Road (E),  
Shanghai 200002, China  
Tel: +86-21-6335-1560 Fax: +86-21-6335-1605  
<http://cn.fujitsu.com/fmc>

**FUJITSU MICROELECTRONICS PACIFIC ASIA LTD.**  
10/F, World Commerce Centre, 11 Canton Road  
Tsimshatsui, Kowloon  
Hong Kong  
<http://cn.fujitsu.com/fmc/tw>

Specifications are subject to change without notice. For further information please contact each office.

#### All Rights Reserved.

The contents of this document are subject to change without notice. Customers are advised to consult with sales representatives before ordering. The information, such as descriptions of function and application circuit examples, in this document are presented solely for the purpose of reference to show examples of operations and uses of FUJITSU MICROELECTRONICS device; FUJITSU MICROELECTRONICS does not warrant proper operation of the device with respect to use based on such information. When you develop equipment incorporating the device based on such information, you must assume any responsibility arising out of such use of the information. FUJITSU MICROELECTRONICS assumes no liability for any damages whatsoever arising out of the use of the information. Any information in this document, including descriptions of function and schematic diagrams, shall not be construed as license of the use or exercise of any intellectual property right, such as patent right or copyright, or any other right of FUJITSU MICROELECTRONICS or any third party or does FUJITSU MICROELECTRONICS warrant non-infringement of any third-party's intellectual property right or other right by using such information. FUJITSU MICROELECTRONICS assumes no liability for any infringement of the intellectual property rights or other rights of third parties which would result from the use of information contained herein. The products described in this document are designed, developed and manufactured as contemplated for general use, including without limitation, ordinary industrial use, general office use, personal use, and household use, but are not designed, developed and manufactured as contemplated (1) for use accompanying fatal risks or dangers that, unless extremely high safety is secured, could have a serious effect to the public, and could lead directly to death, personal injury, severe physical damage or other loss (i.e., nuclear reaction control in nuclear facility, aircraft flight control, air traffic control, mass transport control, medical life support system, missile launch control in weapon system), or (2) for use requiring extremely high reliability (i.e., submersible repeater and artificial satellite). Please note that FUJITSU MICROELECTRONICS will not be liable against you and/or any third party for any claims or damages arising in connection with above-mentioned uses of the products. Any semiconductor devices have an inherent chance of failure. You must protect against injury, damage or loss from such failures by incorporating safety design measures into your facility and equipment such as redundancy, fire protection, and prevention of over-current levels and other abnormal operating conditions. Exportation/release of any products described in this document may require necessary procedures in accordance with the regulations of the Foreign Exchange and Foreign Trade Control Law of Japan and/or US export control laws. The company names and brand names herein are the trademarks or registered trademarks of their respective owners.