

## BEFORE CLEANING

Open the ADF while pulling the cover open lever

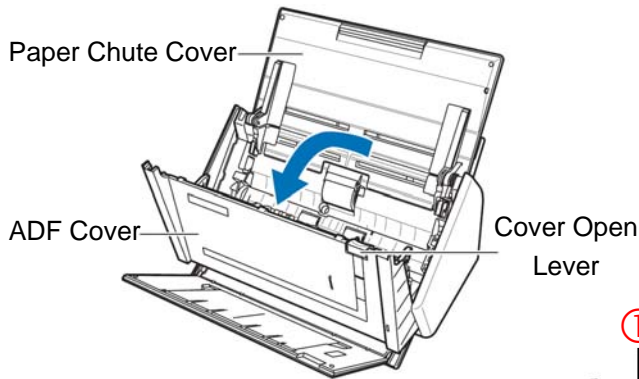

It is recommended that these items be cleaned **EVERY 1,000 SCANS**

Consumables	Part Number
Consumable Kit	CON-3360-001A
Cleaning Kit	SC-CLE-SS

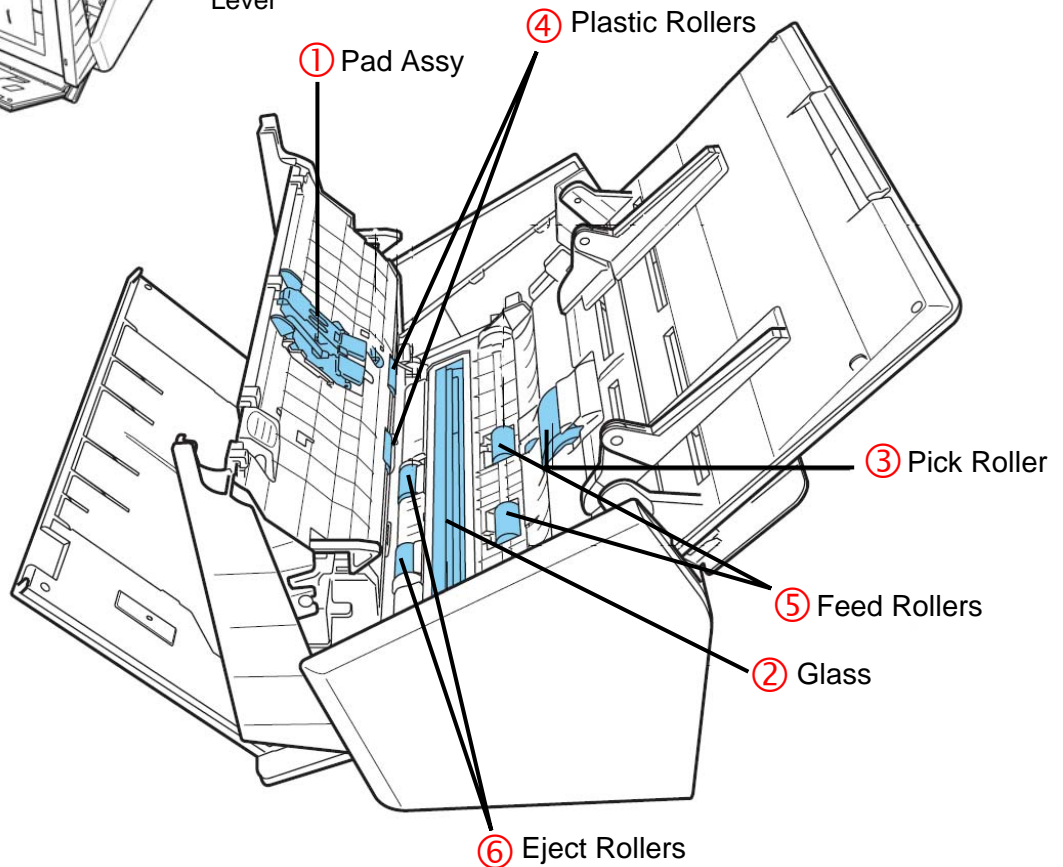

Turn the Scanner **OFF** while cleaning the following locations

### Using F1 Impregnated Cleaning Wipes

#### ① Pad Assy

Wipe downwards. When cleaning take care to prevent the cleaning wipe from catching on the metal parts

#### ② ADF Glass Surfaces x 2

Located on the ADF cover and opposite side. Clean lightly.

#### ③ Pick Roller

Clean lightly taking care not to scratch the surface.

#### ④ Plastic Rollers x 4

Clean lightly while rotating with your finger. Take care not to roughen the surface.

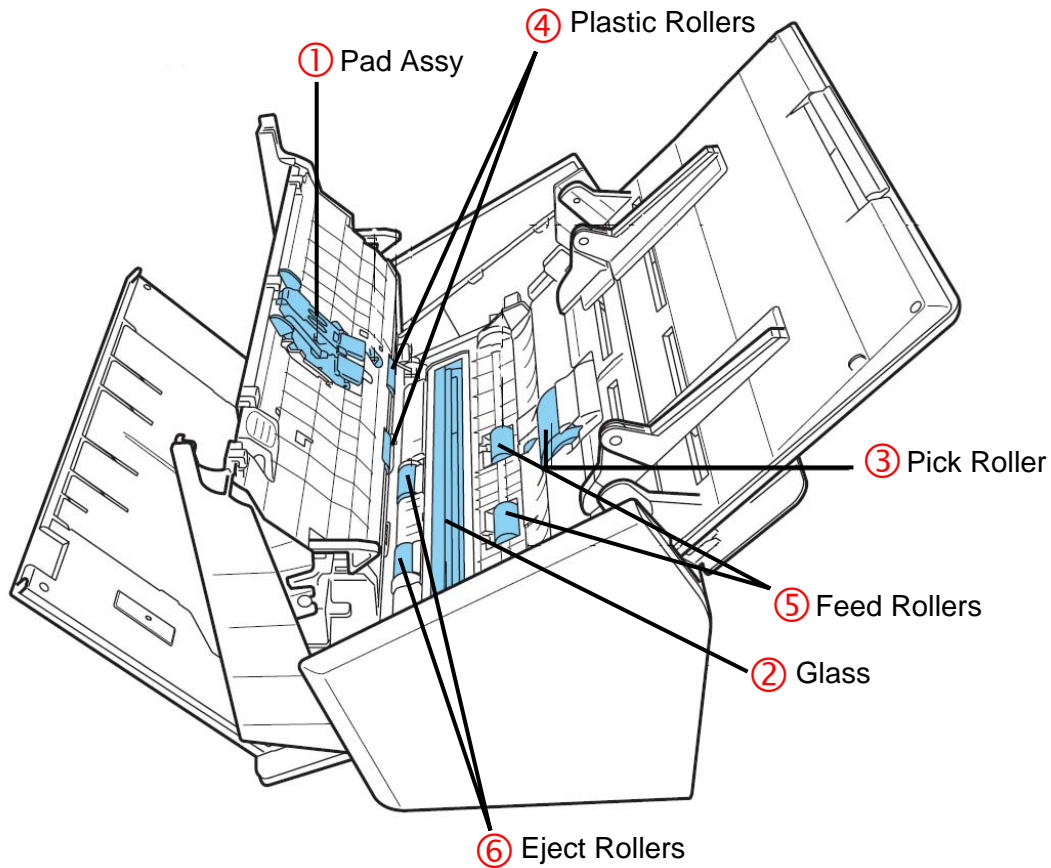

**Turn the Scanner **ON** while cleaning the following locations**

**Using F1 Impregnated Cleaning Wipes**

To rotate the Feed and Eject Rollers, press the POWER button while holding down the SCAN button. As a guideline, six presses of the POWER button makes the rollers rotate one full turn.

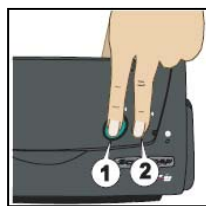

While holding down the SCAN button ①

Press the POWER button ②

Each press of the POWER button will cause the rollers to rotate

**⑤ Feed Rollers x 4**

Clean lightly while rotating with your finger. Take care not to roughen the surface.

**⑥ Eject Rollers x 2**

Clean lightly taking care not to roughen the surface.

**For further information please refer to the **ScanSnap S1500/S1500M Operators Guide** which can be found on our Website: <http://www.fujitsu.com/emea/products/>**