

MAW3300NC/NP, MAW3147NC/NP, MAW3073NC/NP DISK DRIVES INSTALLATION GUIDE



CARE OF YOUR FUJITSU DRIVE

Careful handling and installation of your disk drive is paramount to the longevity of the unit. Serious damage can occur to the internal mechanisms if forces outside the environmental specifications are exerted to the casing. In transportation, always use the original packing in which the drive was supplied and avoid sharp changes in temperature to minimise the risk of condensation.

Handling

1. **Never** drop. Handle with care.
2. **Never** move the disk drive while the disks are spinning. This is when the drive is powered on and also immediately after power off. Refer to the Start/Stop specification for your drive.
3. **Always** turn off the power before connecting or disconnecting the interface cable. The same applies to changing any of the switches or terminal settings except Write protect switch on NP model drives.
4. **Never** place the drive in the vicinity of strong magnetic fields such as monitors, televisions, or loudspeakers.
5. **Never** use any cleaning agents or liquids on the drive.
6. **Always** use an antistatic mat and wrist strap when handling the drive. Hold the drive by the Base casting and never touch the components on printed circuit board.
7. **Never** remove any labels from the drive and do not deface them in any way; these labels are part of the disk drive design.
8. **Never** open the disk enclosure for any reason. Doing so voids any warranty.
9. **Always** pay close attention to the mounting specifications such as sway space and cooling. If the temperature difference between storage location and installation locations is more than 10°C, leave the drive in the new location for at least two hours for Temperature acclimation. This minimises any risk of condensation forming on the drive.

The Drive needs NO preventative or periodic maintenance during its life time if properly used in the correct environment.

INSTALLATION

1. **ORIENTATION**—The drive can be installed in each six surface down orientations. Inclination from vertical or horizontal should not exceed 5°.
2. **MOUNTING SCREW INSTALLATION**—When the mounting screw holes on the side of the drive are used, be sure to use the two pairs of outer holes. Do not use the center hole in conjunction with only one of the outer holes. The screws must not penetrate the drive by more than 5.0 millimeters. Impact caused by the electric driver must be within the device specifications.
3. **COOLING**—Allow space above and below the drive to provide an adequate air flow. Fan cooling is recommended. The disk enclosure temperature measured at center of base cover (label side) should never exceed 60°C. See Table 1.

Table 1. Reference value of airflow

Environmental temperature	Required velocity of airflow
35°C	> 0.2m/s
40°C	> 0.5 m/s
45°C	> 0.9 m/s
50°C	> 1.5 m/s

4. **TERMINATION**—A terminator should be installed externally at both ends of the SCSI bus.
5. **TERMINATOR POWER**—Terminator power must be supplied to terminator for correct operation. This can be supplied from either the drive, except for NC model or the SCSI bus. If only NC model drives are connected to the SCCI bus, terminator power should be supplied externally.
6. **ATTACHING THE CABLES**—To avoid possible damage to the drive, make sure the direction of the connector matches.

CAUTION: Warranty may be avoided if damage to the connector is caused by wrong insertion.

Diagram and user-selectable options (on NP models only)

Below is a diagram of the main board of SCSI disk drives and also a summary of the user-selectable options including guidelines for installation of the drives.

This setting applies only for NP model drives.

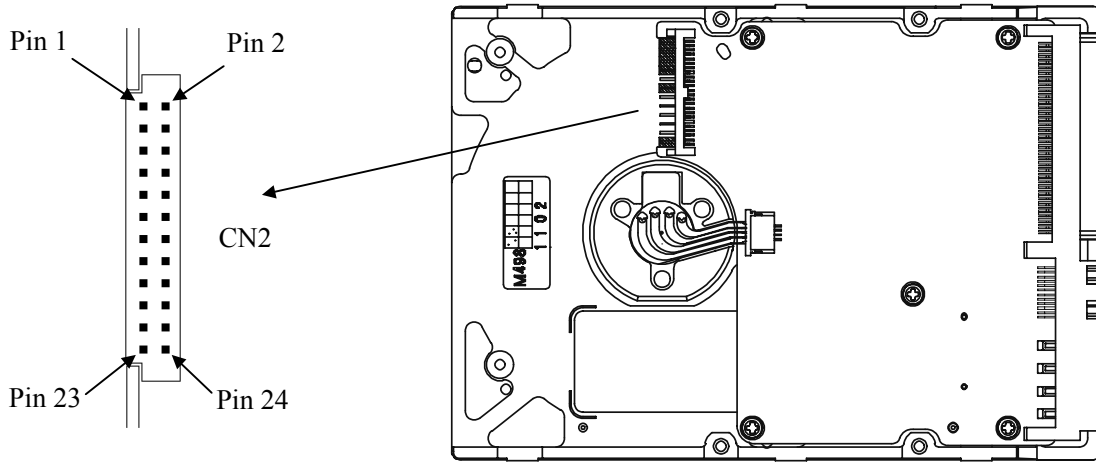

Figure 1. Option select terminal

Table 2. CN2 Terminal Setting (on NP models only)

Pin #	Setting Item	Function	
1-2	SCSI ID 0	See Table 3.	
3-4	SCSI ID 1		
5-6	SCSI ID 2		
7-8	SCSI ID 3		
9-10	Write protect	OpenWrite operation is enabled.	(default)
		ShortWrite operation is disabled.	
11-12	Motor start mode	OpenStarting of motor is controlled with START/STOP UNIT command.	(default)
		ShortMotor is started immediately after power supply is turned on or microcode is downloaded.	
13-14	Force Narrow	Open16-bit bus mode	(default)
		ShortPull upper 8bits and parity internally when drive is connected to Narrow SCSI bus.	
15-16	Force Single Ended	OpenFollows DIFFSNS signal level on SCSI bus.	(default)
		ShortSingle-Ended mode	
17	GND		
18, 19	N.C		
20	IDD Reset	Input signal	
21-22	Remote LED	Output signal	
23-24	Terminal power supply	OpenDrive does not supply terminator power to SCSI bus.	
		ShortDrive supplies terminator power to SCSI bus.	(default)

Table 3. SCSI ID Setting on CN2 (on NP models only)

Pin 1-2	Pin 3-4	Pin 5-6	Pin 7-8	ID	Pin 1-2	Pin 3-4	Pin 5-6	Pin 7-8	ID	
Open	Open	Open	Open	0	Open	Open	Open	Short	8	
Short	Open	Open	Open	1	Short	Open	Open	Short	9	
Open	Short	Open	Open	2	Open	Short	Open	Short	10	
Short	Short	Open	Open	3	Short	Short	Open	Short	11	
Open	Open	Short	Open	4	Open	Open	Short	Short	12	
Short	Open	Short	Open	5	Short	Open	Short	Short	13	
Open	Short	Short	Open	6	Open	Short	Short	Short	14	
Short	Short	Short	Open	7	Short	Short	Short	Short	15	(default)