

## CHAPTER 3 Installation Conditions

- 3.1 Dimensions
- 3.2 Mounting
- 3.3 Connections with Host System

This chapter gives the external dimensions, installation conditions, surface temperature conditions, cable connections, and switch settings of the hard disk drives.

### 3.1 Dimensions

Figure 3.1 illustrates the dimensions of the disk drive. All dimensions are in mm.

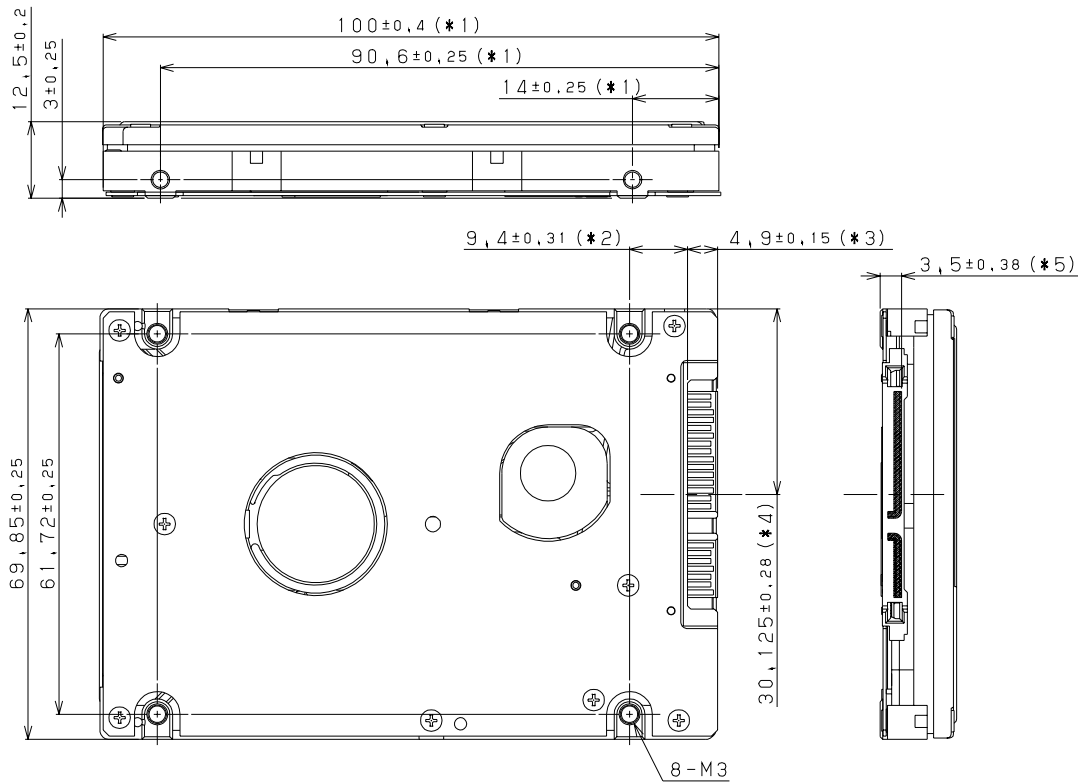

- \*1 The PCA and connectors are not included in these dimensions.
- \*2 Dimension from the center of the user tap to the base of the connector pins
- \*3 Length of the connector pins
- \*4 Dimension from the outer edge of the user tap to the center of the connector pins
- \*5 Dimension from the outer edge of the user tap to the innermost edge of the connector pins

**Figure 3.1 Dimensions**

## 3.2 Mounting

For information on mounting, see the "FUJITSU 2.5-INCH HDD INTEGRATION GUIDANCE (C141-E144)."

### (1) Orientation

The disk drives can be mounted in any direction.

### (2) Frame

The MR head bias of the HDD disk enclosure (DE) is zero. The mounting frame is connected to Signal Ground (SG).

#### IMPORTANT

Use M3 screw for the mounting screw and the screw length should satisfy the specification in Figure 3.2.

The tightening torque must be  $0.49\text{N} \cdot \text{m}$  ( $5\text{kgf} \cdot \text{cm}$ ).

When attaching the HDD to the system frame, do not allow the system frame to touch parts (cover and base) other than parts to which the HDD is attached.

### (3) Limitation of mounting

Note) These dimensions are recommended values; if it is not possible to satisfy them, contact us.

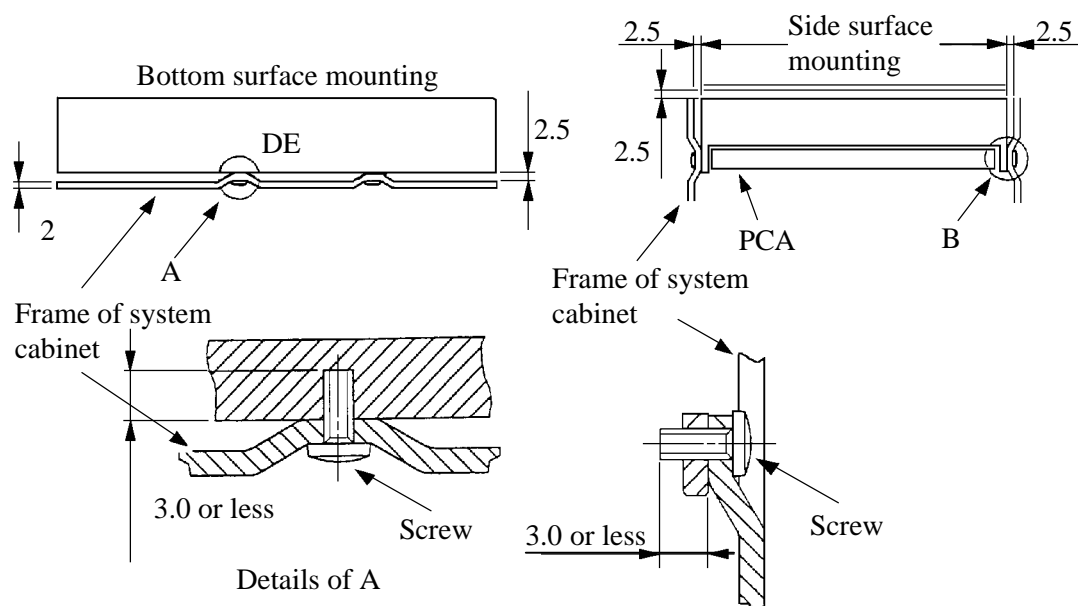

Figure 3.2 Mounting frame structure

**IMPORTANT**

Because of breather hole mounted to the HDD, do not allow this to close during mounting.

Locating of breather hole is shown as Figure 3.3.

For breather hole of Figure 3.3, at least, do not allow it around  $\phi 2.4$  to block.

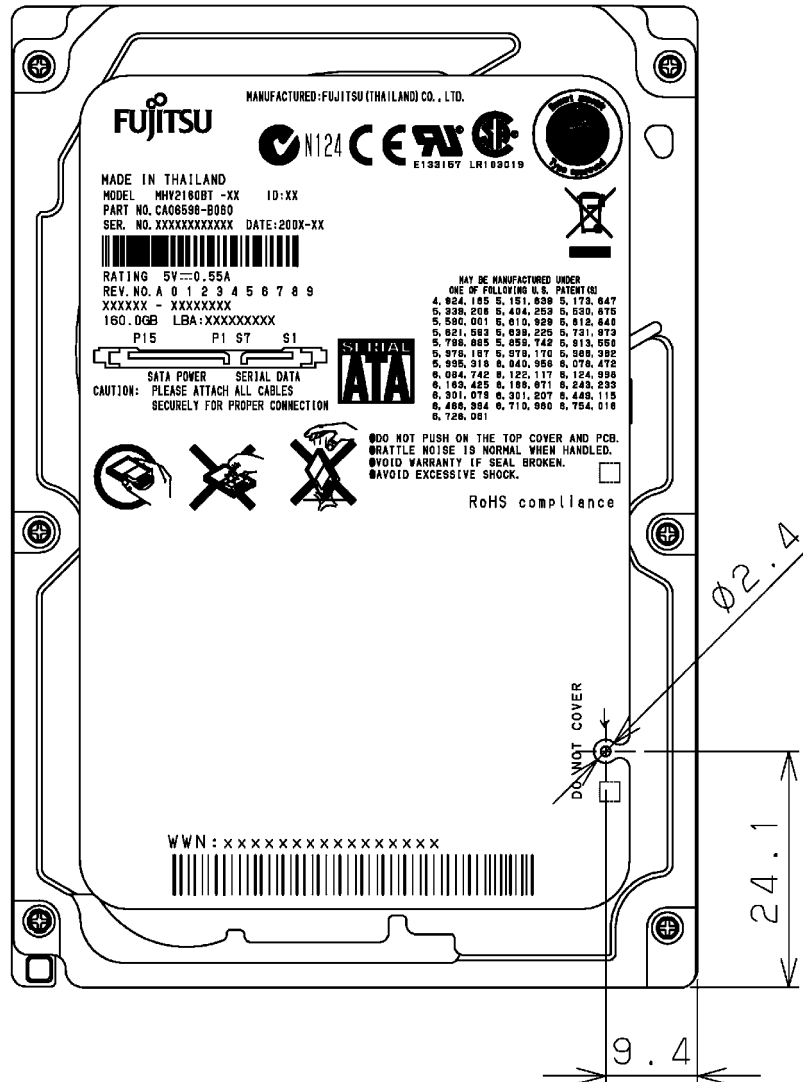
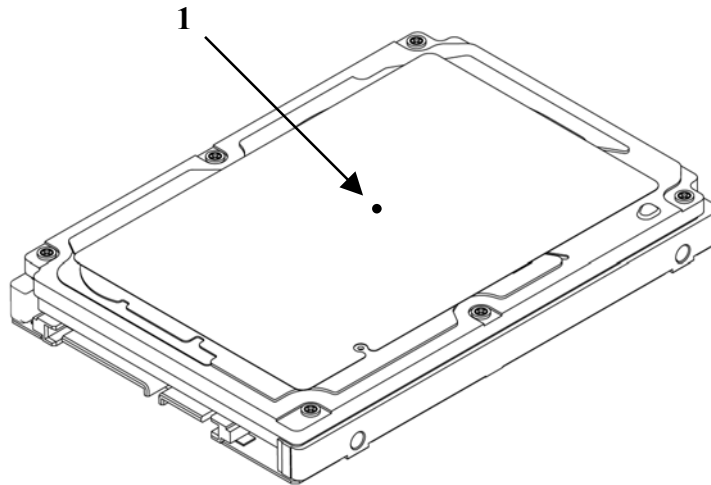

**Figure 3.3 Location of breather**

#### (4) Ambient temperature

The temperature conditions for a disk drive mounted in a cabinet refer to the ambient temperature at a point 3 cm from the disk drive. The ambient temperature must satisfy the temperature conditions described in Section 1.4, and the airflow must be considered to prevent the DE surface cover temperature from exceeding 60 °C.

Provide air circulation in the cabinet such that the PCA side, in particular, receives sufficient cooling. To check the cooling efficiency, measure the surface cover temperatures of the DE. Regardless of the ambient temperature, this surface cover temperature must meet the standards listed in Table 3.1. Figure 3.4 shows the temperature measurement point.



**Figure 3.4 Surface cover temperature measurement points**

**Table 3.1 Surface temperature measurement points and standard values**

No.	Measurement point	Temperature
1	DE cover	60 °C max

(5) Service area

Figure 3.5 shows how the drive must be accessed (service areas) during and after installation.

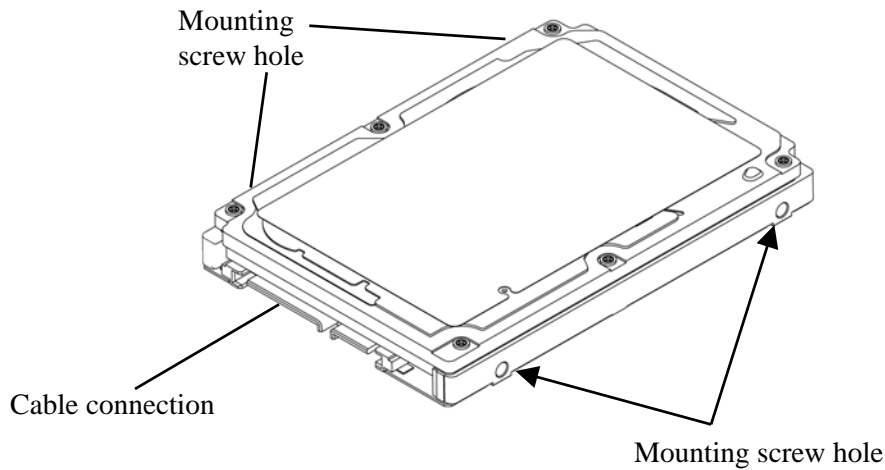

**Figure 3.5 Service area**

**CAUTION**

**Data corruption:** Avoid mounting the disk drive near strong magnetic sources such as loud speakers. Ensure that the disk drive is not affected by external magnetic fields.

**Damage:** Do not press the cover of the disk drive. Pressing it too hard, the cover and the spindle motor contact, which may cause damage to the disk drive.

**Static:** When handling the device, disconnect the body ground (500 k $\Omega$  or greater). Do not touch the printed circuit board, but hold it by the edges.

(6) Handling cautions

Please keep the following cautions, and handle the HDD under the safety environment.

- **General notes**

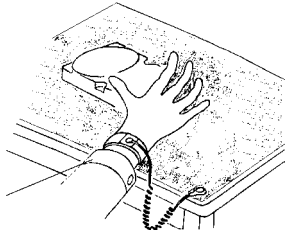

Wrist strap

Use the Wrist strap.

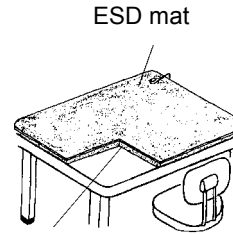

Shock absorbing mat

Place the shock absorbing mat on the operation table, and place ESD mat on it.

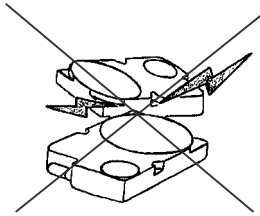

Do not hit HDD each other.

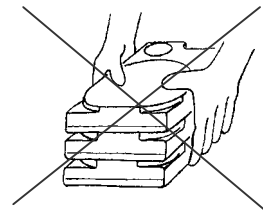

Do not stack when carrying.

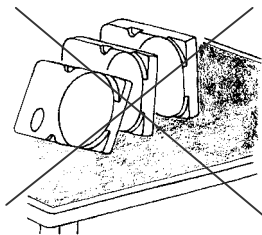

Do not place HDD vertically to avoid falling down.

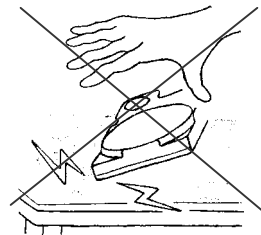

Do not drop.

**Figure 3.6 Handling cautions**

- **Installation**

- (1) Please use the driver of a low impact when you use an electric driver.  
HDD is occasionally damaged by the impact of the driver.
- (2) Please observe the tightening torque of the screw strictly.  
M3 ..... 0.49N • m (5 kgf • cm).

- **Recommended equipments**

	Contents	Model	Maker
ESD	Wrist strap	JX-1200-3056-8	SUMITOMO 3M
	ESD mat	SKY-8A (Color Seiden Mat)	Achilles
Shock	Low shock driver	SS-6500	HIOS

### 3.3 Connections with Host System

#### 3.3.1 Device connector

The disk drive has the SATA interface connectors listed below for connecting external devices. Figure 3.7 shows the locations of these connectors and terminals.

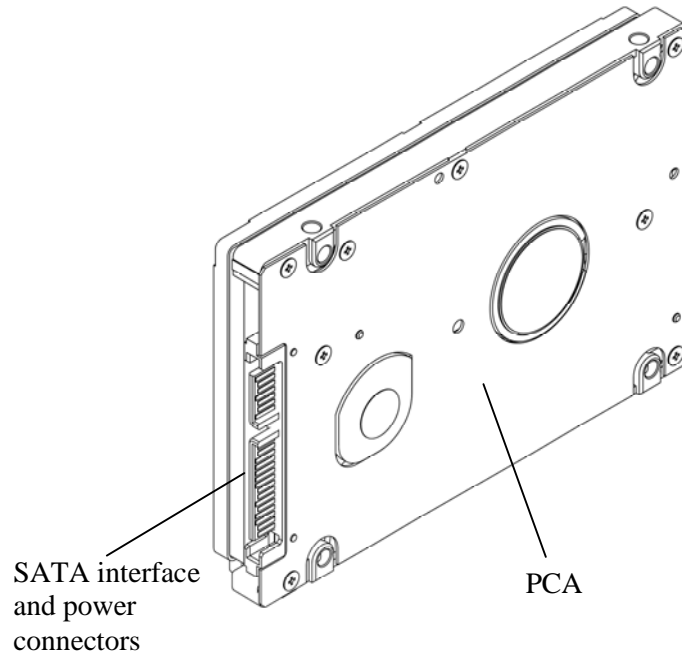
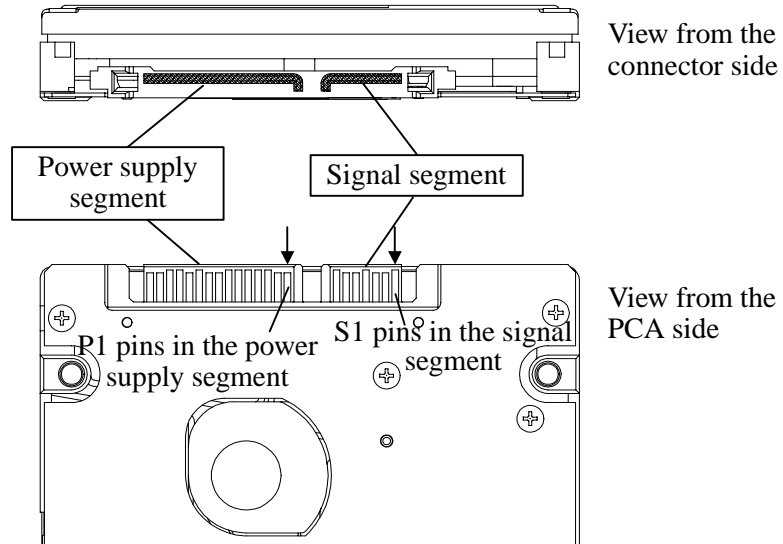

**Figure 3.7 Connector locations**



### 3.3.2 Signal segment and power supply segment

Figure 3.8 shows each segment of the SATA interface connector and pin numbers.



**Figure 3.8 Power supply pins (CN1)**

### 3.3.3 Connector specifications for host system

Table 3.2 lists the recommended specifications for the host interface connectors.

**Table 3.2 The recommended connector specifications for the host system**

Segment	Name	Model (Manufacturer)
SATA interface and power supply	Host receptacle	67492-0220 (Molex) or compatibles

### **3.3.4 SATA interface cable connection**

The cable that connects the disk drive to the host system must be compliant with the Serial ATA 1.0a specification.

### **3.3.5 Note about SATA interface cable connection**

Take note of the following precaution about plugging a SATA interface cable into the SATA interface connector of the disk drive and plugging the connector into a host receptacle:

#### **IMPORTANT**

When plugging together the disk drive SATA interface connector and the host receptacle or SATA interface cable connector, do not apply more than 10 kgf of force in the connection direction once they are snugly and securely in position.