

---

---

# M3097E AND M3097G IMAGE SCANNER OPERATOR'S GUIDE

---

---

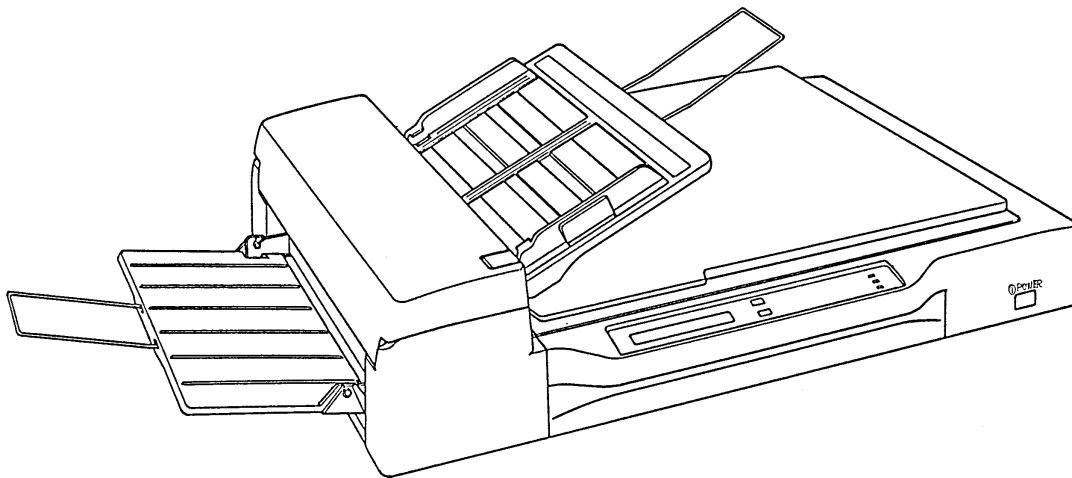

<b>REVISION RECORD</b>		
<b>Edition</b>	<b>Date published</b>	<b>Revised contents</b>
01	Jul., 1992	
02	Sep., 1992	All pages are revised.
03	Jan., 1993	
04	Nov., 1994	Cleaning procedure and so forth are revised.
05	Sep., 1995	Pad replacement procedure added and error correction.
06	Oct., 1995	NOTICE added.
07	Jun., 1996	Document counter instruction added.
Specification No.: 50FH5038E-07		

This digital apparatus does not exceed the Class A limit for radio noise emissions from digital apparatus set out in the Radio interference Regulations of the Canadian Department of Communications.

Le présent appareil numérique n'émet pas de bruits radioélectriques dépassant les limites applicables aux appareils numériques de la classe A prescrites dans le Règlement sur le brouillage radioélectrique édicté par le ministère des Communications du Canada.

This equipment has been tested and found to comply with the limits for a Class A digital device, pursuant to Part 15 of the FCC Rules. These limits are designed to provide reasonable protection against harmful interference when the equipment is operated in a commercial environment.

This equipment generates, uses, and can radiate radio frequency energy and, if not installed and used in accordance with the instruction manual, may cause harmful interference to radio communications. Operation of this equipment in a residential area is likely to cause harmful interference in which case the user will be required to correct the interference at his own expense.

The contents of this manual is subject to change without prior notice.

All Rights Reserved,  
 Copyright ©1992, 1993, 1994, 1995, 1996  
 FUJITSU LIMITED

## **IMPORTANT NOTE TO USERS**

READ CAREFULLY ALL OF THIS MANUAL BEFORE USING THIS PRODUCT. IF NOT USED CORRECTLY, UNEXPECTED DAMAGES MAY BE CAUSED TO THE USERS OR THE BYSTANDERS.

### **Conventions for Alerts**

This manual uses the following conventions for alerts to prevent physical or property damages to users or bystanders.



**▲CAUTION** indicates that either minor or moderate personal injury may occur if the user does not perform the procedure correctly.



**NOTICE** indicates that inconvenience to the user such as damages to the product, equipment, data, and/or other property may occur if the user does not pay attention or perform the procedure correctly.

**IMPORTANT**

**IMPORTANT** indicates information that helps the user use the product more effectively.

# CONTENTS

	page
<b>CHAPTER 1 PREFACE</b> .....	1-1
<b>CHAPTER 2 COMPONENTS</b> .....	2-1
2.1 Checking the Components .....	2-1
2.2 Part Names and Functions .....	2-2
2.2.1 Exterior view of image scanner .....	2-2
2.2.2 Functions of each part .....	2-3
2.3 Operator Panel Functions .....	2-4
2.3.1 Indicators .....	2-5
2.3.2 Buttons and liquid crystal display screen (M3097E) .....	2-5
2.3.3 Buttons and liquid crystal display screen (M3097G) .....	2-11
2.3.4 Messages .....	2-11
<b>CHAPTER 3 INSTALLATION AND CONNECTIONS</b> .....	3-1
3.1 Precautions .....	3-1
3.2 Removing the Carrier Fixing Bracket .....	3-2
3.3 Connections .....	3-3
3.4 Mounting the Stacker .....	3-5
<b>CHAPTER 4 OPERATIONS</b> .....	4-1
4.1 Turning on the Power .....	4-1
4.2 Reading a Document in Flatbed Mode .....	4-2
4.2.1 Reading a standard-size document .....	4-2
4.2.2 Reading a page from a thick book .....	4-3
4.2.3 Reading a document larger than the document board .....	4-4
4.3 Reading Documents in ADF Mode .....	4-5

<b>CHAPTER 5 MAINTENANCE .....</b>	<b>5-1</b>
5.1 Removing Jammed Documents .....	5-1
5.2 Notes on Daily Use .....	5-2
5.3 Cleaning .....	5-2
5.3.1 Cleaning the document cover, document holding pad, and document bed .....	5-2
5.3.2 Cleaning the ADF .....	5-3
5.3.3 Cleaning the coupled feed roller .....	5-4
5.3.4 Cleaning the mirror .....	5-4
5.4 Replacing the Lamp Unit .....	5-5
5.5 SCSI Address Setting (M3097G) .....	5-9
5.6 Replacing the pad .....	5-10
5.7 Document counter display and reset .....	5-11
 <b>CHAPTER 6 TROUBLESHOOTING .....</b>	 <b>6-1</b>
 <b>APPENDIX .....</b>	 <b>A-1</b>
A.1 Installation Specifications .....	A-1
A.2 External Dimensions .....	A-2

# FIGURES

	page
Figure 2.1 Received components .....	2-1
Figure 2.2 M3097E/G parts names .....	2-2
Figure 2.3 M3097E operator panel .....	2-4
Figure 2.4 M3097G operator panel .....	2-4
Figure 4.1 Flatbed reading .....	4-3
Figure 4.2 Removing the document cover .....	4-4
Figure 4.3 ADF paper chute setting .....	4-6
Figure 4.4 Loading the document .....	4-8
Figure 5.1 Removing jammed documents.....	5-1
Figure 5.2 Cleaning the document cover, document holding pad, and document bed .....	5-2
Figure 5.3 Cleaning the ADF .....	5-3
Figure 5.4 Lamp unit removal 1 .....	5-6
Figure 5.5 Lamp unit removal 2.....	5-6
Figure 5.6 Lamp unit replacement .....	5-7
Figure 5.7 Inserting the glass .....	5-8
Figure 5.8 Removing the pad .....	5-10
Figure A.1 External dimensions.....	A-2

**This page is intentionally left blank.**

# TABLES

	page
Table 1.1 The differences between the M3097E and the M3097G .....	1-1
Table 6.1 Check items .....	6-1
Table A.1 Installation specifications .....	A-1

**This page is intentionally left blank.**

# CHAPTER 1 PREFACE

This manual describes how to operate the M3097E and M3097G image scanners. An image scanner optically reads image information from a document and outputs the information to the host system. The differences between the M3097E and the M3097G image scanners are listed in table 1.1.

**Table 1.1 The differences between the M3097E and the M3097G**

Model number	Interface	Shipping destination	Image size	Automatic document feeder
M3097E	RS232C + VIDEO	North America	A3 size or double-letter size	Yes
		Europe		
M3097G	SCSI2	North America		
		Europe		

This manual should be read before operating the image scanner to ensure correct operation.

## Note on Copyright Act

This document cannot be reproduced or copied for any use other than private without the author's permission.

**This page is intentionally left blank.**

# CHAPTER 2 COMPONENTS

- 2.1 Checking the Components
- 2.2 Part Names and Functions
- 2.3 Operator Panel Functions

After unpacking image scanner, confirm that all the components have been received. This section describes the components of the image scanner and their functions.

## 2.1 Checking the Components

These high precision components must be handled with care. Confirm that all the components shown in figure 2.1 have been received. If any component is missing, please contact your local Fujitsu sales person.

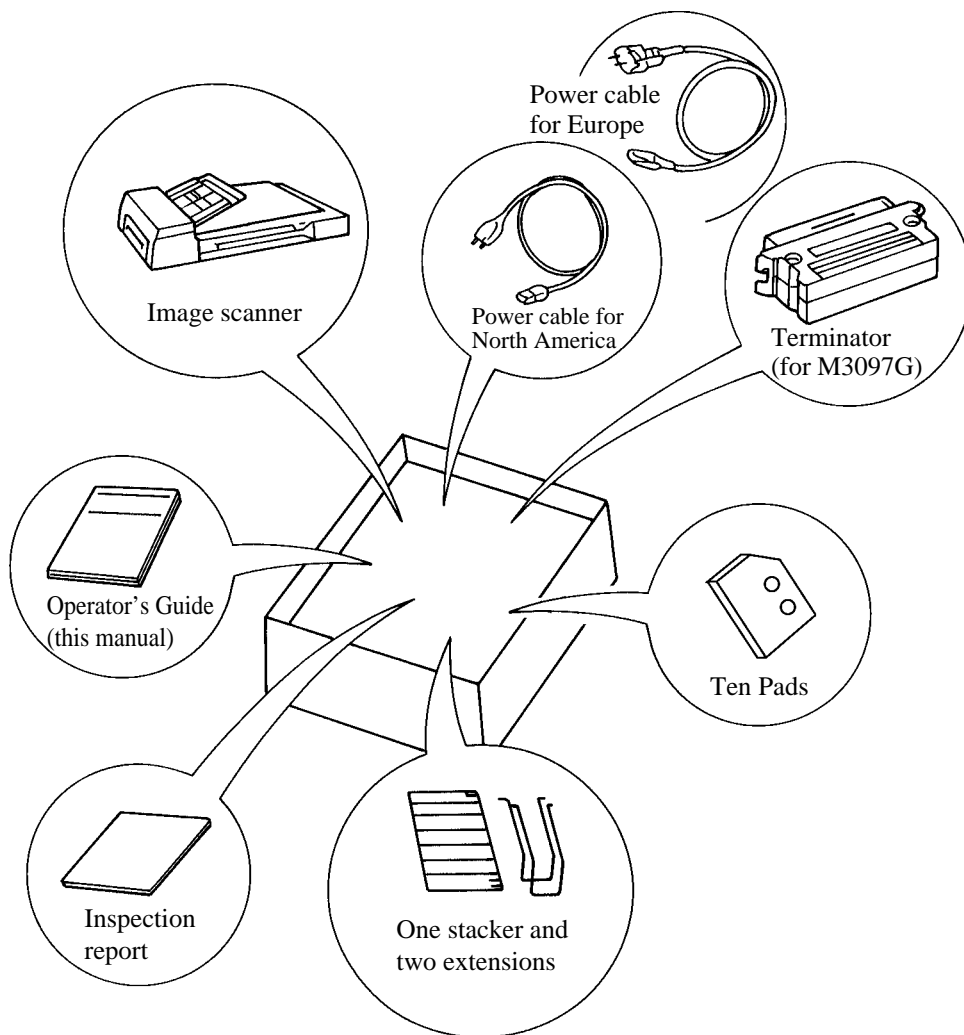

Figure 2.1 Received components

## 2.2 Part Names and Functions

This section shows the exterior view of image scanner. This section also provides names of each part and describes their functions.

### 2.2.1 Exterior view of image scanner

The image scanner can read a document of A3 or double-letter size at maximum.

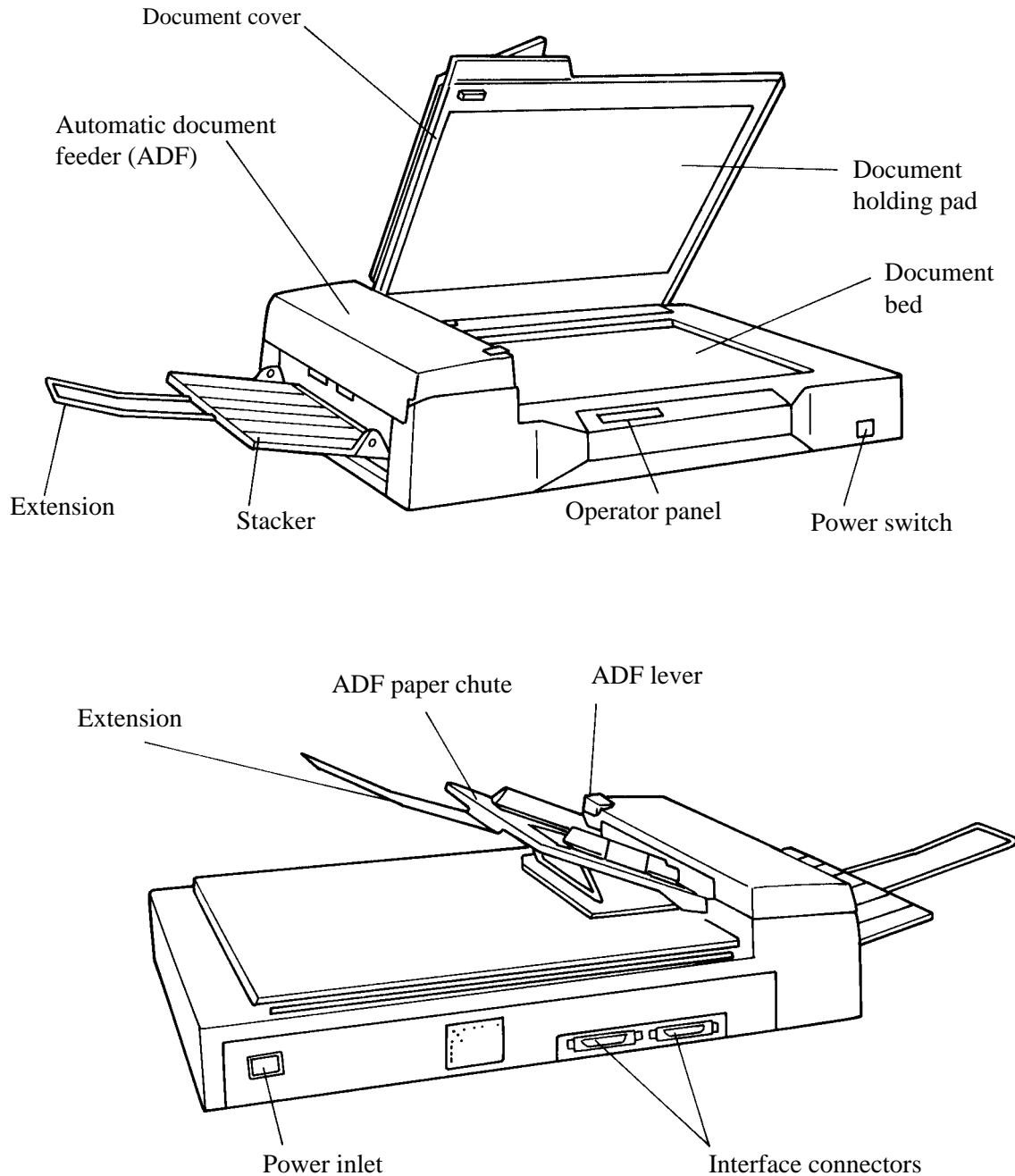

Figure 2.2 M3097E/G parts names

### 2.2.2 Functions of each part

Document cover:	Closed over and holds a document to be read.
Document bed:	A document to be read is placed on the bed also called Flatbed (FB).
Document holding pad:	Presses a document to the document bed.
Automatic document feeder (ADF):	Automatically feeds documents to the reading position.
Stacker:	Stacks the read documents.
Extension:	Keeps the stacked documents from overhanging.
Power switch:	Turns the power on or off.
Operator panel:	Used to control image scanner operations. See the next section for details of the functions.
ADF paper chute:	Holds the documents to be fed by the automatic document feeder.
ADF lever:	Opens or closes the automatic document feeder to remove documents jammed in the feeder.
Power inlet:	To be connected to an AC power outlet with the power cable.
Interface connectors:	To be connected to the host system with interface cables.

## 2.3 Operator Panel Functions

The operator panel has indicators and a liquid crystal display screen for displaying image scanner status. The operator panel also has operation buttons.

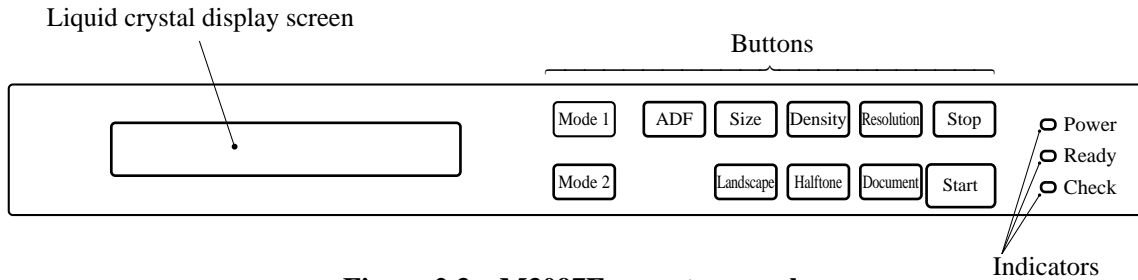

Figure 2.3 M3097E operator panel

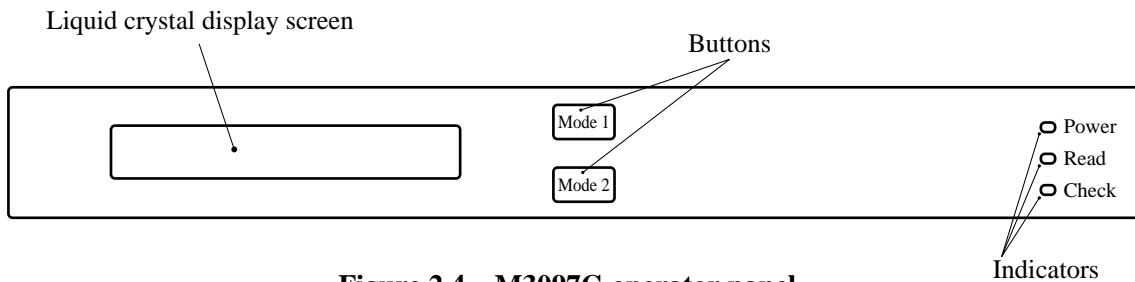

Figure 2.4 M3097G operator panel

### 2.3.1 Indicators

The meaning of each indicator is as follows:

**Power indicator (Green):**

Lights to indicate the power is on.

**Ready (for reading) indicator (Green) (M3097E):**

Lights when the image scanner becomes ready to read a document in the manual mode. This indicator turns off when the start button is pressed to read a document.

**Read (reading in progress) indicator (Green) (M3097G):**

Lights to indicate reading is in progress.

**Check (device check) indicator (Yellow):**

Lights if a device error occurs which may result in a service call. An error message is displayed on the liquid crystal display screen. This indicator blinks if a document is jammed in the automatic document feeder. This indicator turns off when the jammed documents are removed from the feeder and the feeder is closed.

### 2.3.2 Buttons and liquid crystal display screen (M3097E)

The function of each button is as follows:

**Start button:**

Read operation can be started in either manual or automatic mode. To start reading in manual mode, press this button while the ready indicator is lit.

- Manual mode: Reading is started by the start button.
- Automatic mode: Reading is started by a command from the host system.

**Stop button:**

This button is effective regardless of whether the scanner is in manual or automatic mode. Press this button to stop the read operation. When this button is pressed, the image scanner operates as follows:

- Reading in flatbed mode: Reading is immediately stopped.
  - Reading in ADF mode: Reading is immediately stopped and documents being fed are ejected to the stacker.
- After cleaning a jam, press the stop button to clear the “Paper Jam” message displayed on the screen. The ready screen will then be displayed to indicate that the scanner is ready to read.

## Liquid crystal display screen

The screen has two message lines. The current read mode status is displayed in the upper line, and messages and the modes set by the buttons are displayed in the lower line.

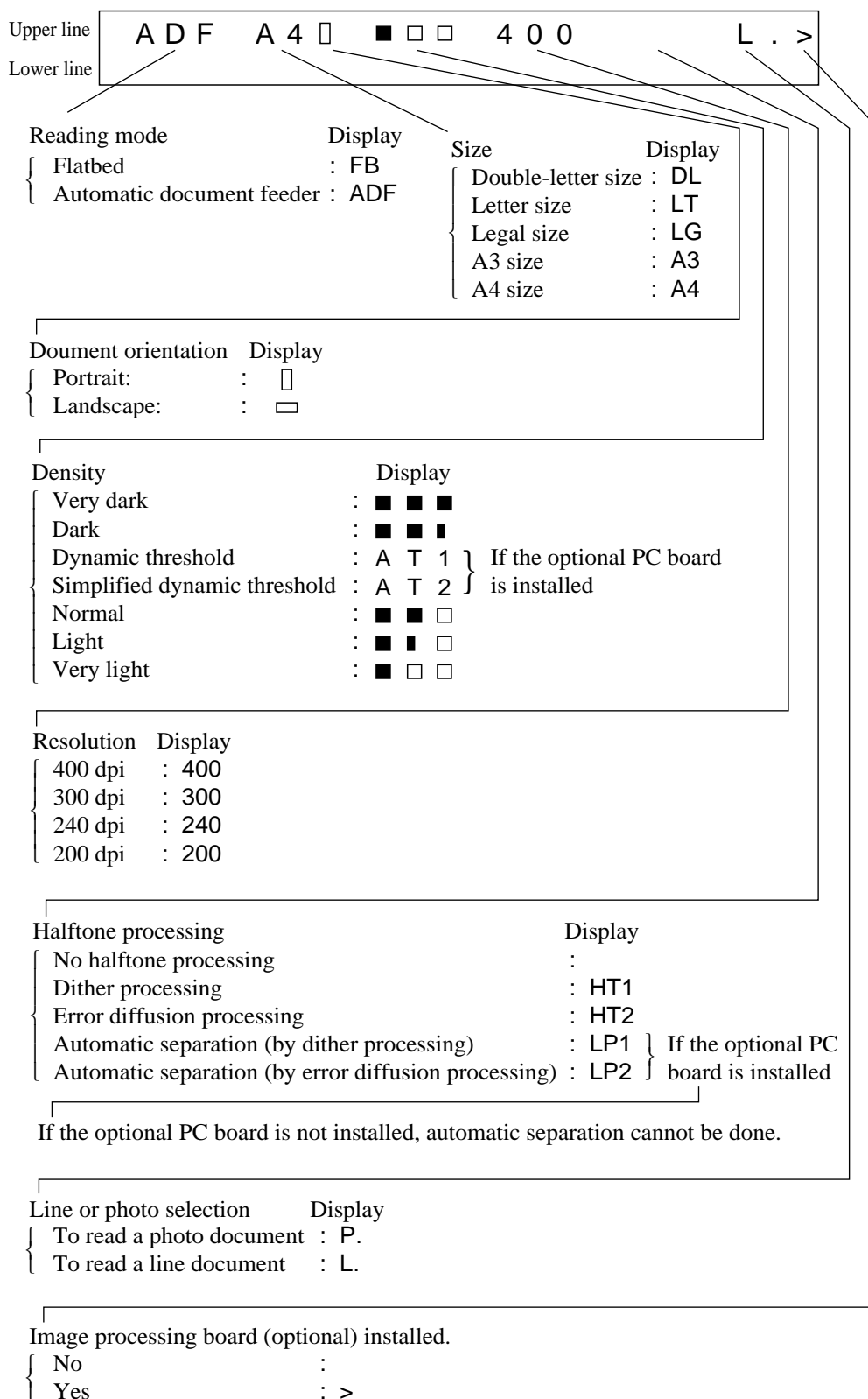

The ADF, size, density, resolution, landscape, half-tone, document, and mode 1 and 2 buttons described below are effective unless otherwise specified by the host system.

**Automatic document feeder (ADF) button:**

Selects whether to feed documents automatically by ADF or manually on the flatbed. When this button is pressed, the lower line is displayed as shown in Screen 1. Each time this button is pressed, “FB” or “ADF” starts blinking in turn, and the read operation status displayed in the upper line changes accordingly.

Screen 1 — The upper line shows a typical example.

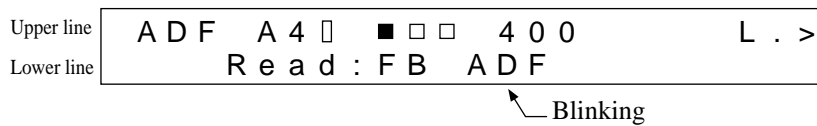

**Size button:**

Selects a document size. When this button is pressed, the lower line is displayed as shown in Screen 2. Each time this button is pressed, “DLT”, “LT”, “LG”, “A3”, or “A4” starts blinking in turn, and the size displayed on the upper line changes accordingly.

Screen 2 — The upper line shows a typical example.

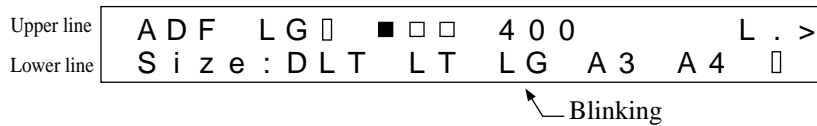

If the direction indicated on the upper line is “□”, only “LT” or “A4” can be selected.

**Density button:**

Selects a density for the read operation. When this button is pressed, the lower line is displayed as shown in Screen 3. Each time this switch is pressed, the blinking part in the lower line changes, and the density indicated on the upper line changes according to the blinking part.

Screen 3 — The upper line shows a typical example.

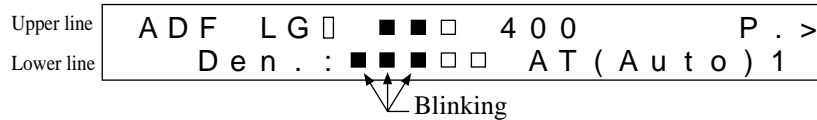

The lower line is displayed as shown below. (See the beginning of this section for the upper line.)

	Display (lower line)	Explanation	
↓ Blinking order ↓	■ ■ ■ ■ ■	— Very dark	
	■ ■ ■ ■ □	— Dark	
	If the optional PC board is installed:	{ AT ( A u t o ) 1	— Dynamic threshold
		{ AT ( A u t o ) 2	— Simplified dynamic threshold
	■ ■ ■ □ □	— Normal	
	■ ■ □ □ □	— Light	
■ □ □ □ □	— Very light		

**Resolution button:**

Selects a resolution for the read operation. When this button is pressed, the lower line is displayed as shown in Screen 4. Each time this button is pressed, “400”, “300”, “240”, or “200” starts blinking in turn, and the resolution indicated on the upper line changes accordingly.

Screen 4 — The upper line shows a typical example.

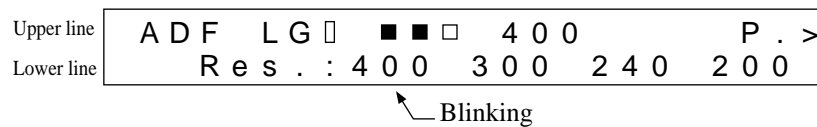

**Landscape button:**

Specifies whether reading is done in landscape or portrait mode. When this button is pressed, the lower line is displayed as shown in Screen 5. Each time this button is pressed, the blinking part changes in turn, and the mode indicated on the upper line changes accordingly.

Screen 5 — The upper line shows a typical example.

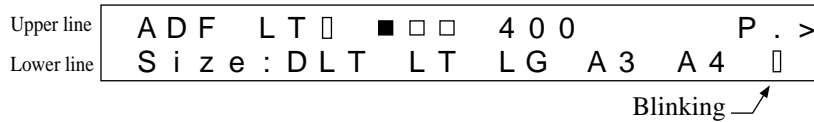

Explanation:

Display

□ : Landscape mode. This mode can be selected only if the document size displayed on the upper line is LT or A4.

□ : Portrait mode.

**Halftone button:**

Specifies whether to perform halftone processing (dither or error diffusion). When this button is pressed, the lower line is displayed as shown in Screen 6. Each time this button is pressed, the blinking part changes in turn, and the halftone indication on the upper line changes accordingly.

Screen 6 — The upper line shows a typical example.

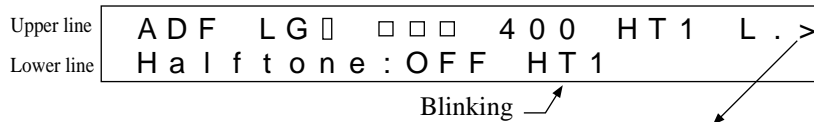

Explanation:

Blinking order	Display (lower line)	Explanation	
	“OFF” blinking	: Line Art (Halftone Processing off)	
	“HT1” blinking	: Halftone processing (dither)	} Select one of these settings to read data such as photographs, illustrations, or colored maps.
	“HT2” blinking (changed from HT1)	: Halftone processing (error diffusion)	
	“LP1” blinking (changed from HT2)	: Automatic separation (dither)	} If photographs and characters are mixed in a document, the characters are read clearly and the photographs are read in halftone. This setting is only available if the optional PC board is installed.
	“LP2” blinking (changed from LP1)	: Automatic separation (error diffusion)	

**Document button:**

Selects the type of document. When this button is pressed, the lower line is displayed as shown in Screen 7. Each time this button is pressed, “LINE” or “PHOTO” starts blinking in turn, and the document selection indication displayed on the upper line changes accordingly.

Screen 7 — The upper line shows a typical example.

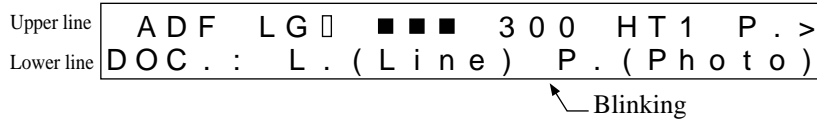

**Explanation:**

Display (lower line)	Explanation
P.(Photo)	: For light adjustment or when there is a dark background color on the document, select P. (Photo).
L.(Line)	: Select this setting to read line drawings.

**IMPORTANT**

When L (Line) is selected, the top 3-mm part of the read area should be left blank (grounding color) by specifying a drop-out color.

- Mode 1 button** : See Sections 5.3.4, 5.4 and 5.5.
  - Mode 2 button** : See Sections 5.3.4, 5.4 and 5.5.
- When error messages are displayed on liquid crystal display screen, press this button to enable the read operation.

### 2.3.3 Buttons and liquid crystal display screen (M3097G)

**Liquid crystal display screen:** Displays messages only.

The mode buttons have the following functions:

**Mode 1 button:** See Section 5.3.4, 5.4 and 5.5.

**Mode 2 button:** See Section 5.3.4, 5.4 and 5.5.

When error messages are displayed on liquid crystal display screen, press this button to enable the read operation.

### 2.3.4 Messages

#### **Error messages (temporary errors)**

If a temporary error occurs in the scanner, one of the following messages is displayed.

P a p e r   E m p t y

This message is displayed if there is no more paper on the ADF paper chute during a read operation in ADF mode. Fill the ADF paper chute with paper. To enable the read operation, for the M3097E, press the stop button, for the M3097G, press the Mode 2 button.

P a p e r   J a m

This message is displayed if a document is jammed in the ADF. See section 5.1 for removing jammed documents.

A D F   -   C o v e r   O p e n

This message is displayed if the ADF is not closed completely. Close the ADF completely, and enable the read operation.

L a m p   -   C o v e r   O p e n  
→ P o w e r   O f f ! !

This message is displayed if the ADF is open for lamp replacement when the power is on. Turn off the power, and close the ADF completely.

### Device errors

One of the following messages is displayed if an device errors in the scanner. If one of the following error messages is displayed, turn the power off and then on again. If the same message is displayed again, contact your service representative.

Optical Alarm

Heater Alarm

Mechanical Alarm

Fuse Alarm - Lamp

Fuse Alarm - Heater

Fuse Alarm - FB Motor

Fuse Alarm - ADF Motor

### Operation status messages

Operation status is displayed as shown by the following messages:

Warming - up Now !!

The power is on.

Now Reading !

Reading is in progress.

Please clean-up !!

The glass plate is dirty. Clean it. In addition, clean the mirror as explained in Section 5.3.4.

Please clean Pick-roller

The pick roller is dirty. Clean it as explained in Section 5.3.2.

ADF LG  400 H  
Ready

The scanner is ready for operation in the manual mode. Press the start button to start the read operation.

M3097E

Scanner Ready

The scanner is ready for operation.

M3097G

## CHAPTER 3 INSTALLATION AND CONNECTIONS

- 3.1 Precautions
- 3.2 Removing the Carrier Fixing Bracket
- 3.3 Connections
- 3.4 Mounting the Stacker

This chapter explains how to install and connect the image scanner.

### 3.1 Precautions

Do not install the image scanner in the following places and environments. See the appendix A.1 “Installation Specifications” for the information such as size of installation space.

---

---

Place the scanner away from electrical noise sources and strong magnetic fields. If the image scanner is used near an air conditioner, copying machine, or TV set, the scanner may operate incorrectly.

---

---

---

---

Do not install the scanner in a humid, dusty, or damp places. These environments may shorten scanner life or cause hardware failures. Do not place the image scanner where liquid spills may occur. Place it on a flat and even surface.

---

---

---

---

Keep the scanner out of the sun and away from heaters. These environments may shorten scanner life or cause hardware failures.

---

---

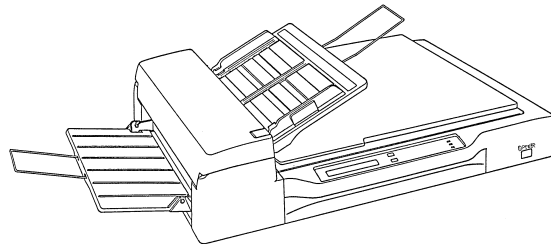

---

---

Do not install the scanner in a place where vibrations may occur. This environment may cause hardware failures or may cause the scanner to operate incorrectly.

---

---

---

---

Be aware of static electricity. If static electricity is generated, the scanner may operate incorrectly. Be sure that the flooring and the desk are made of materials that do not generate static electricity.

---

---

### 3.2 Removing the Carrier Fixing Bracket

To keep the scanner from being damaged during shipping, the carrier unit is fixed with a bracket. After placing the carrier unit at the installation place, remove this bracket as explained below.

- ① Place the image scanner on the edge of the desk top so that the left side (where ADF is placed) of the scanner extends from the desk top. Do not set the image scanner upside down or on its side.

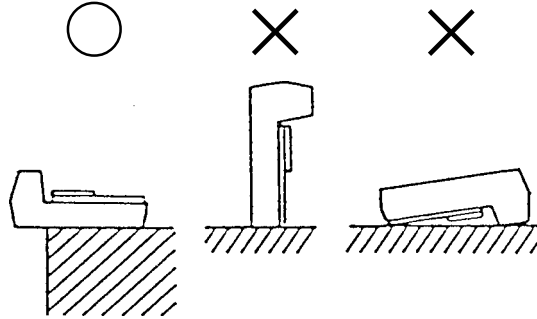

- ② Remove the carrier fixing bracket from position ① Then install the carrier fixing bracket at position ②

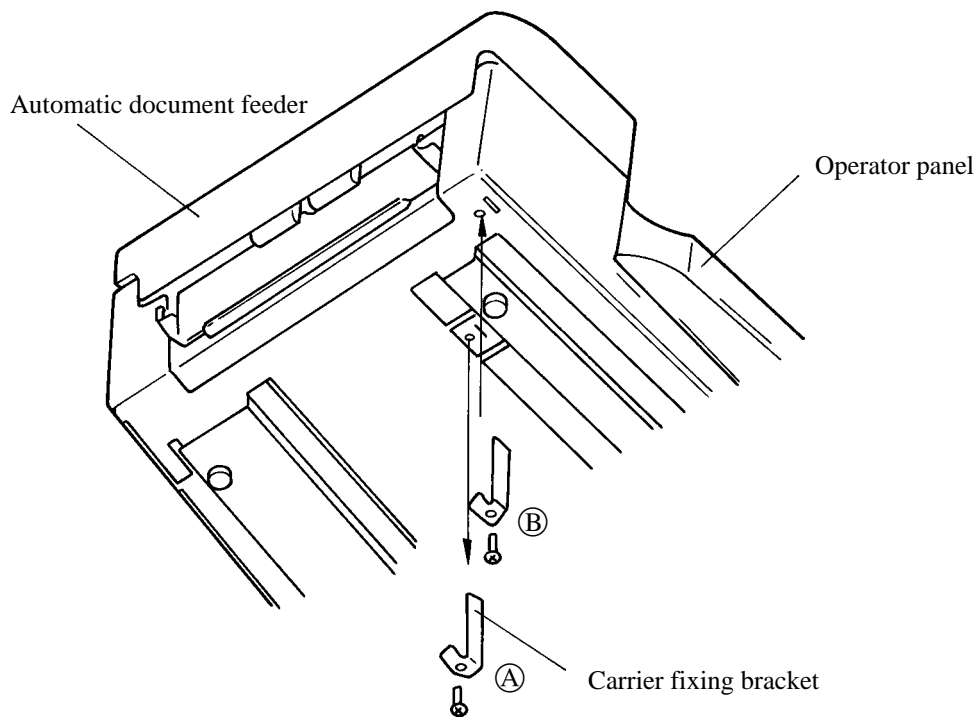

### 3.3 Connections

Connect the image scanner using the following procedure.

- ① Set the power switch to off.

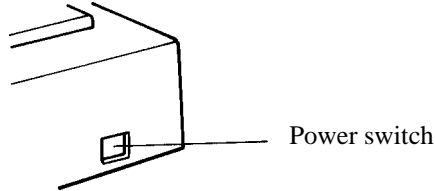

- ② Connect the power cable.  
Connect the power cable to the power inlet on the back of the image scanner.  
Connect the other end of the power cable to a power outlet.

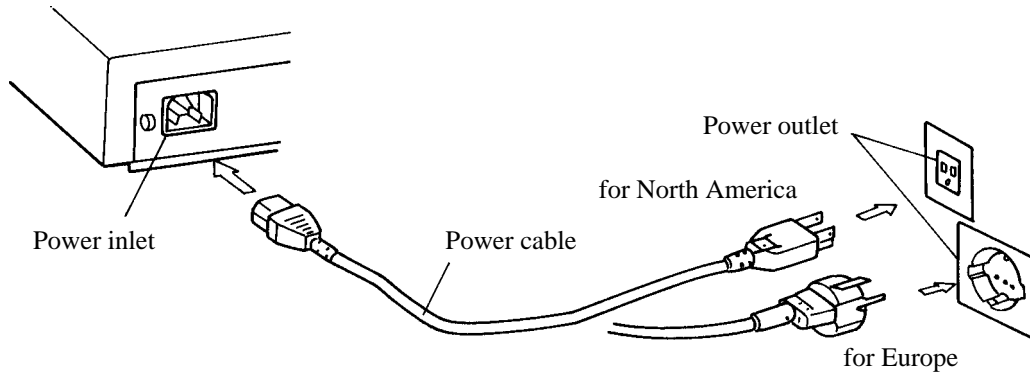

- ③ Connect the interface cables (for M3097E).  
Connect the interface cables to the interface connectors and fasten the cables with catches and screws as shown below.  
Connect the other end of each interface cable to the host computer.

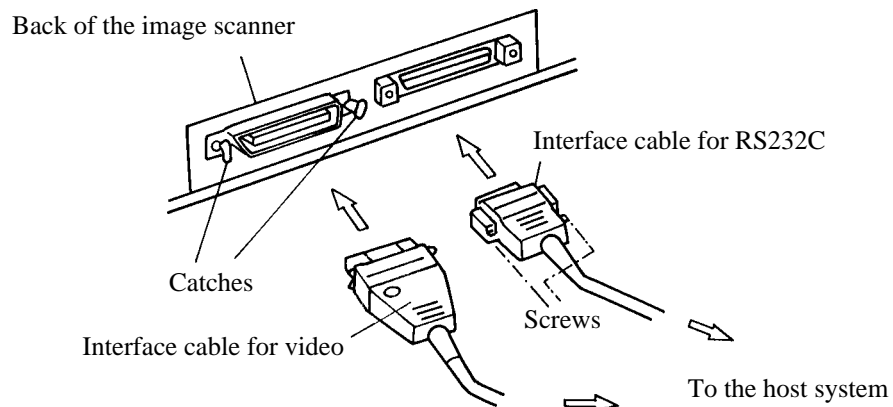

(M3097G)

Connect the interface cables to the interface connectors and fasten the cables with the catches. Connect the other ends of the cables to the host system. If the image scanner is at the terminal side, connect the terminator.

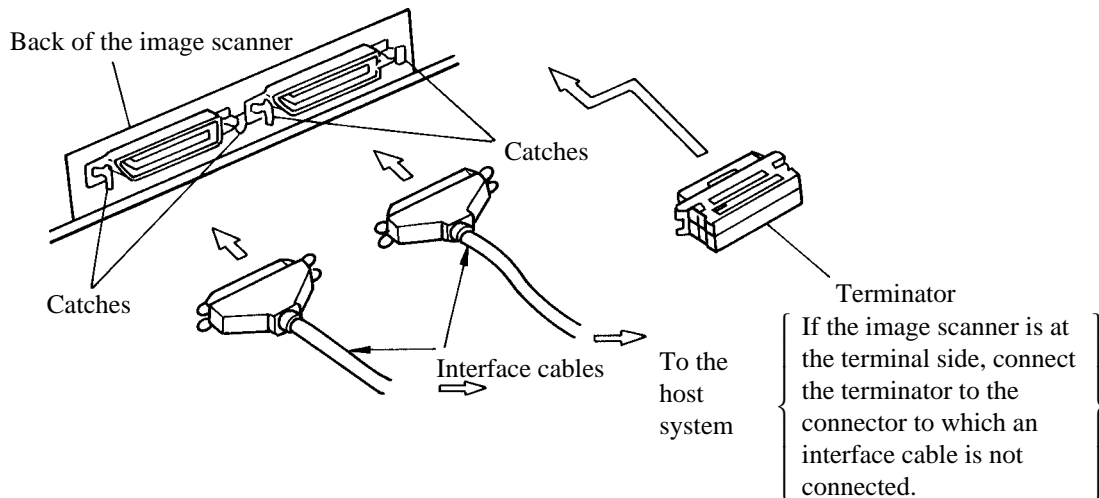

**NOTICE**

Use *shielded* interface cables to prevent harmful interference or avoid receiving interference that may cause undesired operation.

### 3.4 Mounting the Stacker

Mount the stacker and extensions using the following procedure.

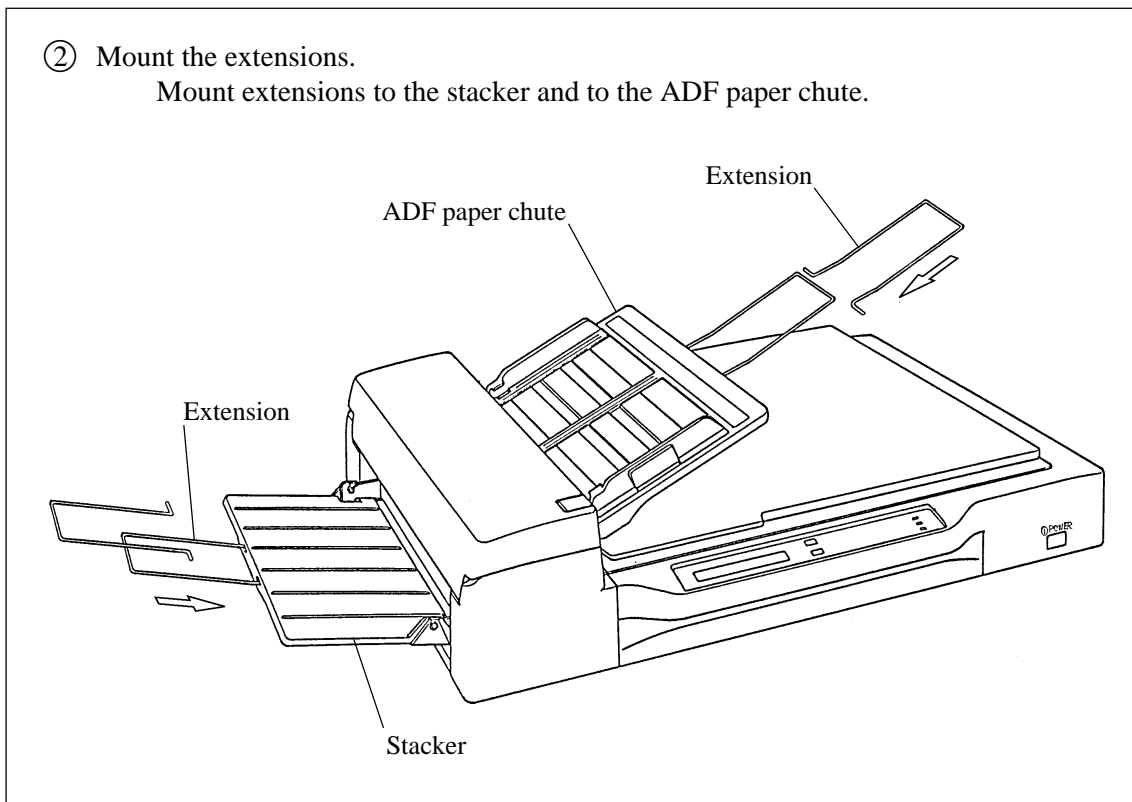
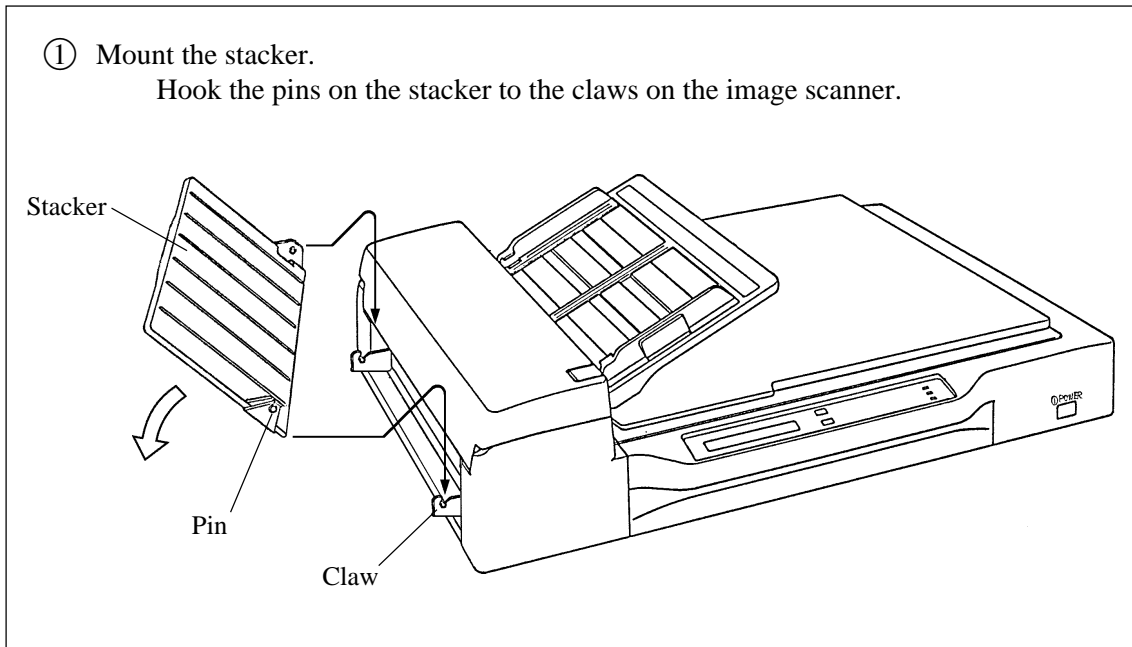

**This page is intentionally left blank.**

# CHAPTER 4 OPERATIONS

- 4.1 Turning on the Power
- 4.2 Reading a Document in Flatbed Mode
- 4.3 Reading Documents in ADF Mode

Documents can be read in the flatbed mode or automatic document feeder (ADF) mode. In the flat-bed mode, each document is placed on the document bed and is read one by one. In ADF mode, documents are fed and read automatically.

This section explains how to turn on the power and how to read documents.

## 4.1 Turning on the Power

This section explains how to turn on the power.

Press the power switch. When the power is turned on, the power indicator is lit.

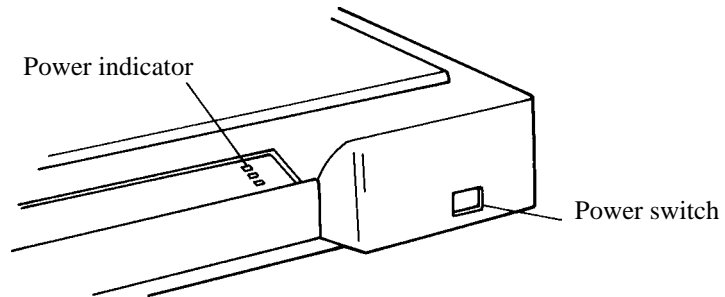

Press the power switch again to turn off the power.

## 4.2 Reading a Document in Flatbed Mode

This section explains how to read a document placed on the document bed.



High luminance: Do not look directly at the light source during read operation. Keep the document cover in place.

### 4.2.1 Reading a standard-size document

If the size of the document is smaller than the document bed, read the document using the following procedure:

- ① Open the document cover.
- ② Place the document face down on the document board. Correct any curled or folded parts of the document.
- ③ Position the long side (in landscape mode) or the short side (in portrait mode) of the document to the left side of the document bed.
- ④ Position the left top of the document to the reference mark. If the document is not placed correctly, reading cannot be done correctly.
- ⑤ Close the document cover slowly. If the document cover is closed too quickly, the document may move.
- ⑥ For M3097E, select a reading mode from the operator panel and start the read operation. For the M3097G, the scanner starts the read operation by a command from the host system. Do not press on or open the document cover during the read operation.
- ⑦ After reading, open the document cover to remove the document.

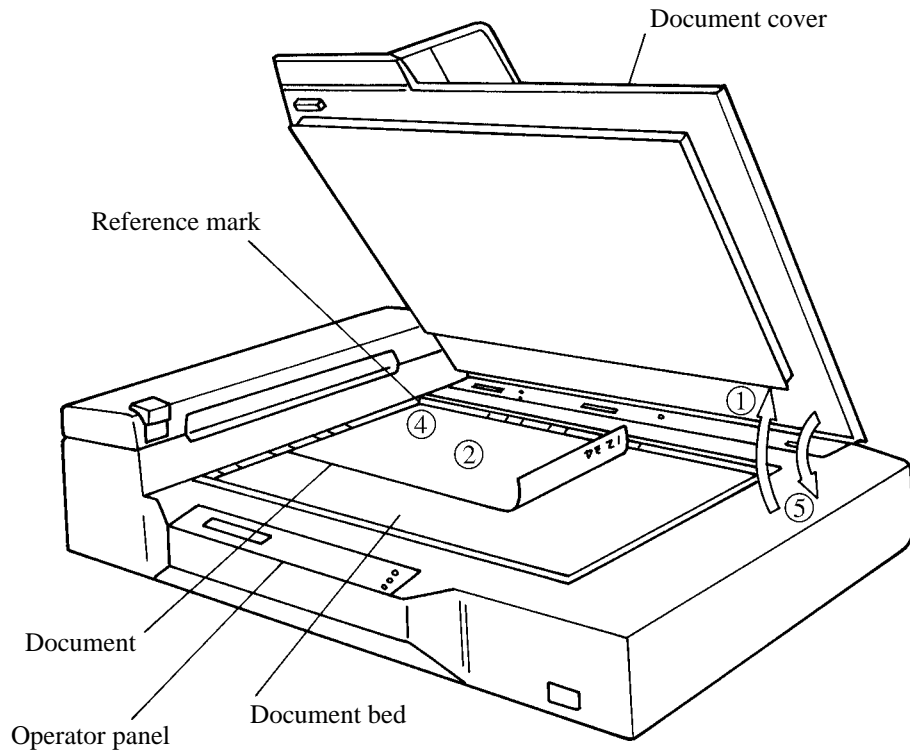

**Figure 4.1 Flatbed reading**

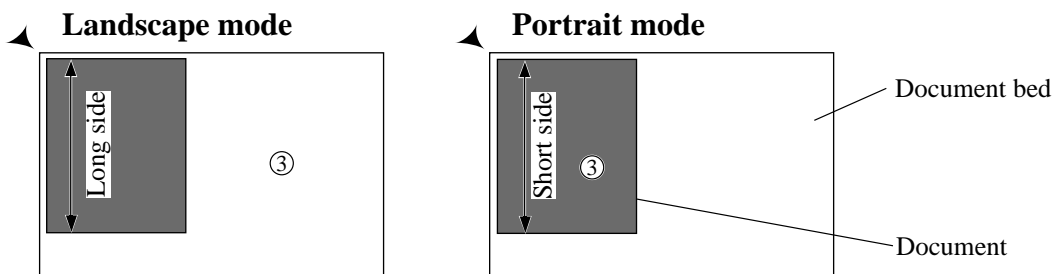

#### 4.2.2 Reading a page from a thick book

To read a page from a thick book, remember the following points:

- ① Do not close the document cover forcibly. Keep the cover open for reading.
- ② Any document parts that are not in contact with the glass will not be read correctly.
- ③ Do not move the document during the read operation.

### 4.2.3 Reading a document larger than the document board

If the size of the document is larger than the document board, read the document using the following procedure:

- ① To remove the document cover, remove the screw from the document cover.
- ② Place the document face down on the document bed.
- ③ Place the document cover over the document.
- ④ Read the document.
- ⑤ After the read operation, remove the document, replace the document cover. Mount the document cover to the original position, fasten the document cover with the screw, and close the document cover.

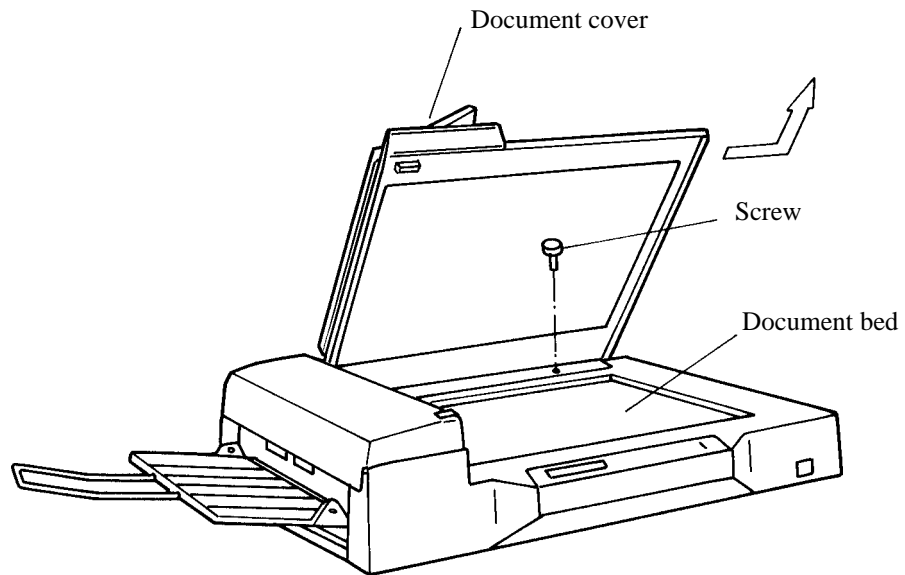

**Figure 4.2 Removing the document cover**

#### **NOTICE**

Do not remove the document cover for any other purpose. Do not use a different screw to fix the document cover to the scanner.

### 4.3 Reading Documents in ADF Mode

This section explains how to read documents using the automatic document feeder. If the following steps are not closely followed, a feed error may occur.

After documents have been read in ADF mode, a squeaking noise is sometimes heard. This is not a problem as the noise is caused by the self-cleaning action of the rollers.

- ① Check the documents as follows:
  - (a) Paper quality
    - Wood-free paper.
    - PPC paper; Specified by XEROX Corporation.
  - (b) Paper weight
    - 13.9 lbs to 34 lbs
  - (c) Paper size
    - Letter, Double Letter, Legal, A3, A4, A5, B4, B5, B6, A6
  - (d) Items to avoid
    - The following paper cannot be fed by ADF appropriately.
      - Paper with a clip or staple.
      - Paper that has ink that is not dry.
      - Paper thickness is not constant, such as an envelope.
      - Paper that has large rumples or curl.
      - Paper that has folds or tears.
      - Tracing paper.
      - Coating paper.
      - Carbonless paper or carbon paper.
      - Paper that is smaller than A6 size or larger than A3 width.
      - Items other than paper, such as clothes, metal sheet, or OHP film.
      - Photographic paper.
      - Paper that has perforations on its side.
      - Paper that has a shape other than square.
      - Paper that is very thin.

② Pull up the ADF paper chute as follows:

- Hold the document cover with one hand and pull up the ADF paper chute with the other hand to unlock the ADF paper chute.

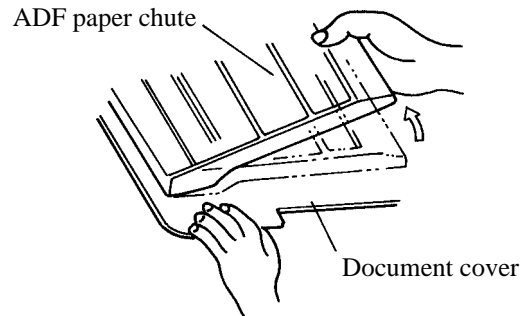

**Figure 4.3 ADF paper chute setting**

③ Fan the documents as follows:

- Take a 15 to 20 mm thickness of documents. Lightly hold both ends with both hands. Bend the documents into an arch as shown below.
- Then hold the documents tightly with both hands, and straighten the documents. The center of documents swell and air is introduced between the documents.
- Repeat this operation two or three times.
- Turn the documents 90°, and repeat the operation again.

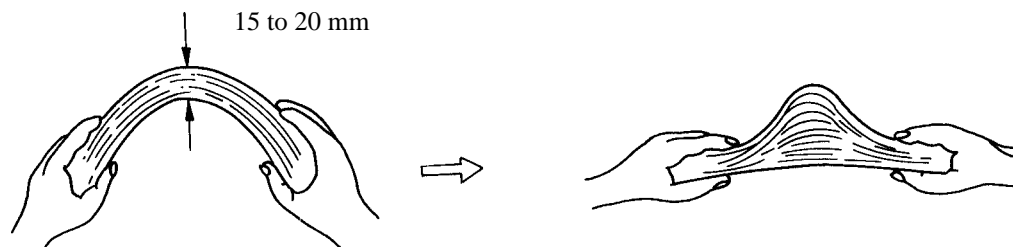

- ④ Take documents to be placed in the ADF paper chute. The thickness of the documents to be placed in the ADF paper chute is limited depending on the size of the documents as follows:

A4 or letter size or smaller: 8 mm or less

Size larger than A4: 4 mm or less

- ⑤ Angling the documents  
Angle the document edges as follows:

- Place the documents face down with the top to the left as shown in A. The long side is the top for landscape mode and the short side is the top for portrait mode.
- Lift the documents holding the both ends with both hands.
- Hold the documents tightly with your left hand and bend the documents as shown in B.
- Grip tightly with your right hand, loosen the grip of your left hand, and straighten the documents as shown in C.
- Repeat these operations until the top is angled 20° or less as shown in D.

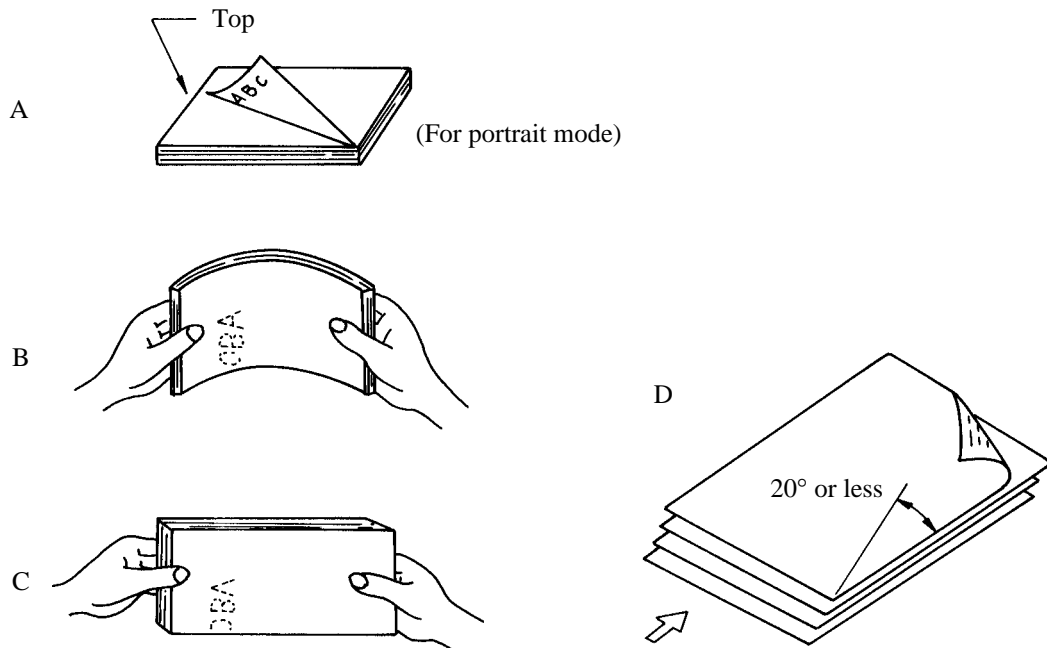

- ⑥ Open the right and left guides of the ADF paper chute about 5 mm wider than the document width.
- ⑦ Place the documents face down onto the ADF paper chute with the top edges facing the automatic feeder hole.
- ⑧ Adjust the guides to the document sides. Skewing may occur if there is a gap between the guides and documents.
- ⑨ Slide the documents down until they touch the far end of the automatic feeder opening. If the documents hit the far end hard, two or more pages may be fed at once. Make sure that the upper end of documents are not turned.
- ⑩ For the M3097E, select the reading mode from the operator panel and start the read operation. For the M3097G, the scanner starts the read operation by a command from the host system. If an incorrect document size or mode (portrait or landscape) is selected, the document may not be read entirely.
- ⑪ After reading, remove the documents from the stacker.

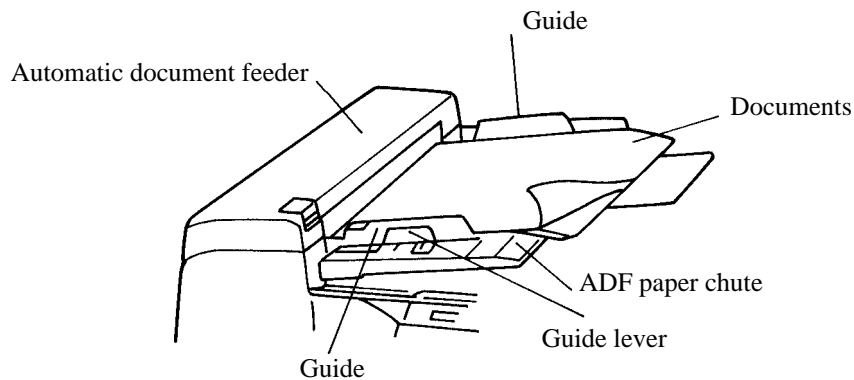

**Figure 4.4 Loading the document**

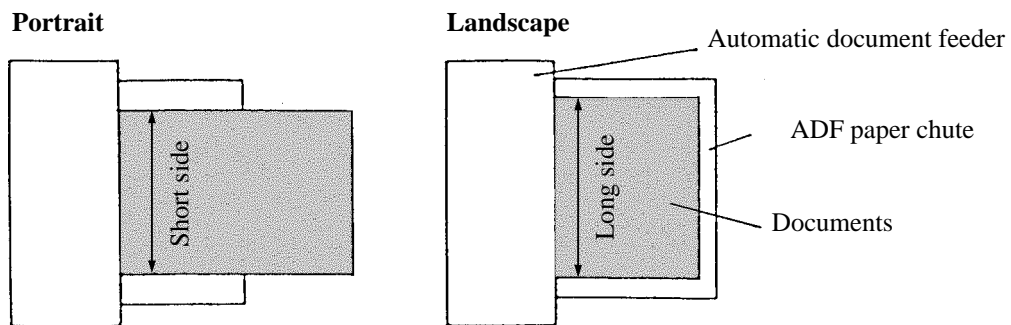

# CHAPTER 5 MAINTENANCE

- 5.1 Removing Jammed Documents
- 5.2 Notes on Daily Use
- 5.3 Cleaning
- 5.4 Replacing the Lamp Unit
- 5.5 SCSI Address Setting (M3097G)
- 5.6 Replacing the Pad

This section explains how to remove jammed documents, and provides notes on daily use and cleaning.

If "Please clean-up!!" is displayed on the operator panel during the read operation, clean the mirror as explained in Section 5.3.4.

If "Please clean Pick-roller" is displayed, clean the pick roller as explained in Section 5.3.2.

## 5.1 Removing Jammed Documents

If documents jam while being fed by the ADF, remove the jammed documents as follows:

- ① Remove the documents from the ADF paper chute.
- ② Pulling up the ADF lever, open the automatic document feeder.
- ③ Remove the jammed documents.
- ④ Close the ADF to the ADF lever.

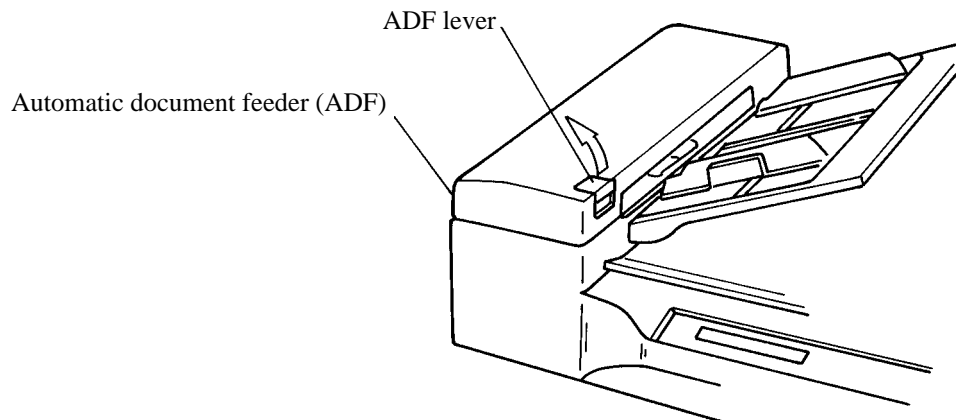

**Figure 5.1 Removing jammed documents**

## 5.2 Notes on Daily Use

Note the following points on daily use:

- The image scanner requires one to three minutes to warm up after the power has been turned on. During this time, the message “Warming-up Now!!” is displayed on the screen.
- Do not look directly at the light source during the read operation. Keep the document cover in place.
- See Section 5.3 “Cleaning”, to clean the document cover, document holding pad, document bed, and the automatic document feeder.

### IMPORTANT

Especially, clean the ADF periodically. For cleaning cycle, see Section 5.3.2 “Cleaning the ADF”.

## 5.3 Cleaning

This section explains how to clean the image scanner.

### 5.3.1 Cleaning the document cover, document holding pad, and document bed

- Use a dry cloth or a cloth with a neutral cleanser or ethyl alcohol to remove dirt from the document cover, document holding pad, and document bed.

### NOTICE

Do not use organic solvents such as a thinner.

- Make sure that no liquid enters the scanner from the edges of the document bed glass.

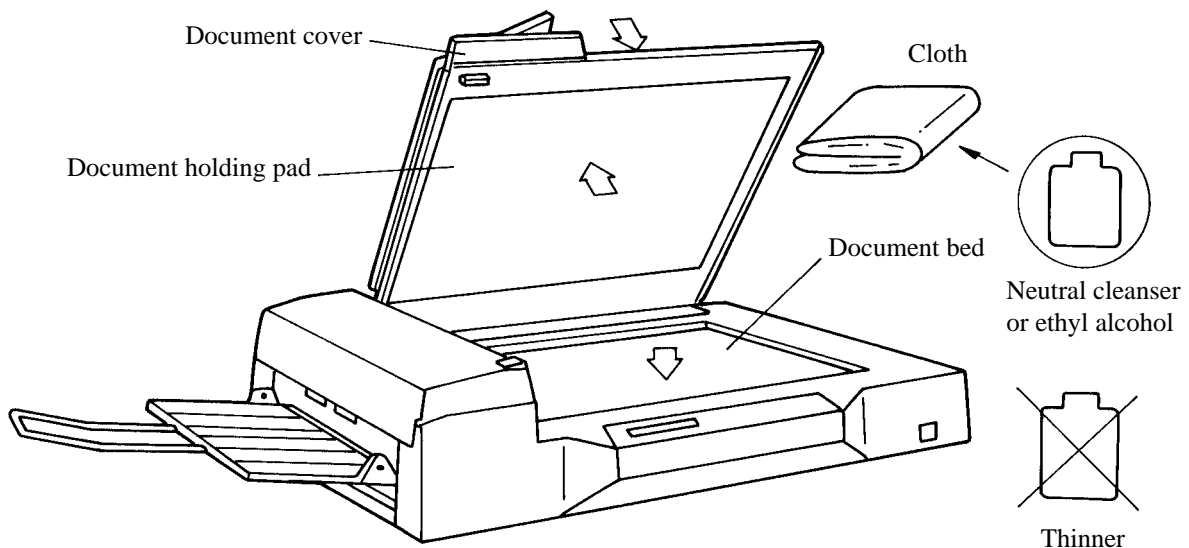

Figure 5.2 Cleaning the document cover, document holding pad, and document bed

### 5.3.2 Cleaning the ADF

Clean the ADF once every 5,000 pages. The cycle depends on the types of documents used (page quality, a level of toner fusing on paper).

- ① Pull the ADF lever up to open the ADF.
- ② Use the dry cloth or a cloth with ethyl alcohol to softly remove dirt and dust as follows.

**Pad:** Wipe the pad in a downward direction (indicated by the arrow). Be careful not to hook the pick spring when wiping.

**Glass:** Wipe the glass lightly. See Section 5.4, “Replacing the Lamp Unit” to clean the bottom of the glass.

**Pick rollers (two):** Wipe the rollers softly. Be careful not to damage the surface of the rollers. If the toner adheres to the roller, it may affect the paper feed performance. Clean the rollers well.

**Feed roller and coupled feed roller:** Wipe the rollers softly. Be careful not to damage the surface of the rollers. If the toner adheres to the roller, it may affect the paper feed performance. Clean the rollers well. For details of the coupled feed roller, see Section 5.3.3.

**Ejection roller and coupled ejection roller:** Wipe the rollers softly. Be careful not to damage the surface of the rollers. If the toner adheres to the roller, it may affect the paper feed performance. Clean the rollers well.

**Guide shaft (white part):** Wipe the guide shaft softly.

- ③ Close the ADF to lock the ADF lever.

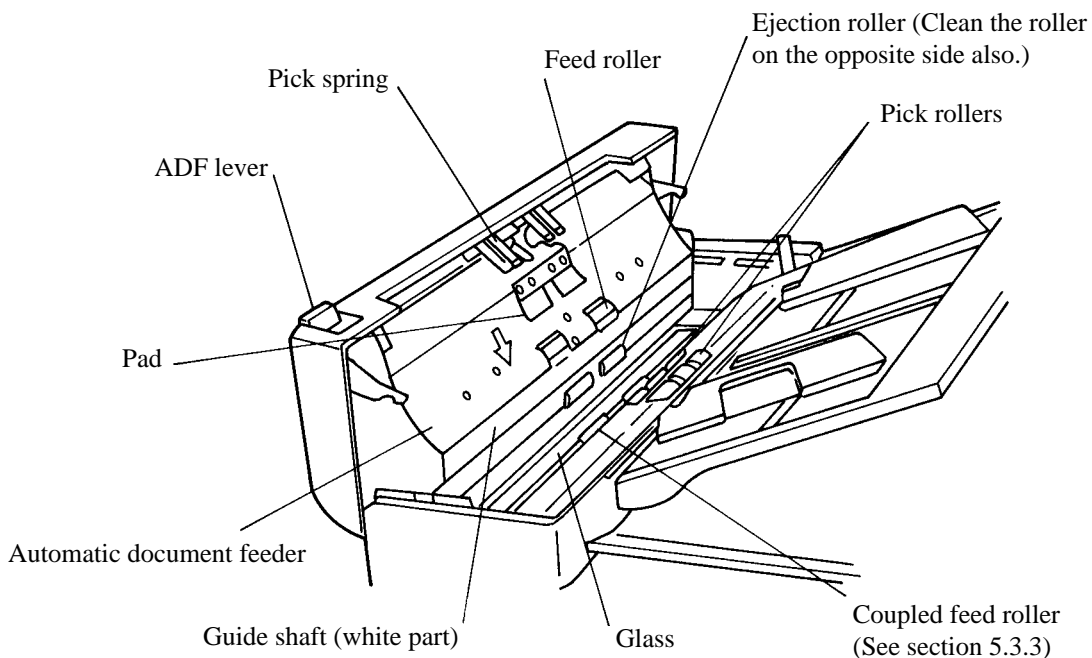

**Figure 5.3** Cleaning the ADF

### 5.3.3 Cleaning the coupled feed roller

- ① Pull the ADF lever up to open the ADF.
- ② Pull the ADF lamp replacement lever up while pushing the lever in the direction indicated by the arrow in Figure 5.4.
- ③ Clean the surface of the coupled feed rollers by the cloth with ethyl alcohol.

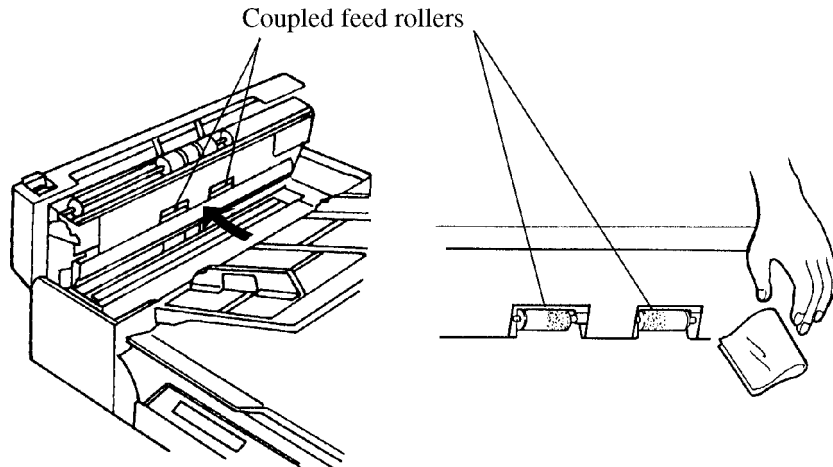

#### **NOTICE**

If the coupled feed rollers are excessively pushed in the direction of the arrow above during cleaning, the automatic document feed performance may be affected.

### 5.3.4 Cleaning the mirror

- ① Cleaning the mirror:  
Remove the glass plate from the automatic document feeder with the same procedure as that for lamp replacement. Do not move the carrier unit during work. Dust may fall on the mirror. When installing the lamp unit, if the automatic document feeder and mirror are dirty, clean them before final installation and before putting the glass plate back on.
- ② How to clean the mirror:  
Wipe the mirror using the blower. When the mirror is very dirty, use a dry cloth or a cloth with alcohol. If the mirror is strongly wiped or dirty cloth is used, the mirror may be damaged.

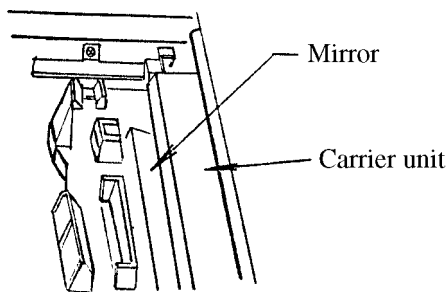

## 5.4 Replacing the Lamp Unit



Hot: Replace the lamp unit in the following procedure.

If an optical alarm occurs, and the following message is displayed, replace the lamp unit as follows.

O p t i c a l   A l a r m

- Turn off the power once. Then, turn on the power while pressing the mode 1 button. For M3097G, press the mode 2 button so that "Lamp Exchange" blinks. If the surface temperature of lamp rises, the following message is displayed:

P l e a s e   w a i t  
L a m p   i s   c o o l i n g   o f f

- After the surface temperature of the lamp lowers, the carrier moves to the replacement position. The lamp remains unlit. Confirm that the following message is displayed.

P o w e r   O f f ! !

Then, turn off the power.

- Pull the ADF lever up and open the ADF.
- Pull the ADF lamp replacement lever up while pushing the lever in the direction indicated by the arrow in Figure 5.4.
- Hold the lamp unit levers and pull the glass up. Wipe the bottom surface of the glass if it is dirty.

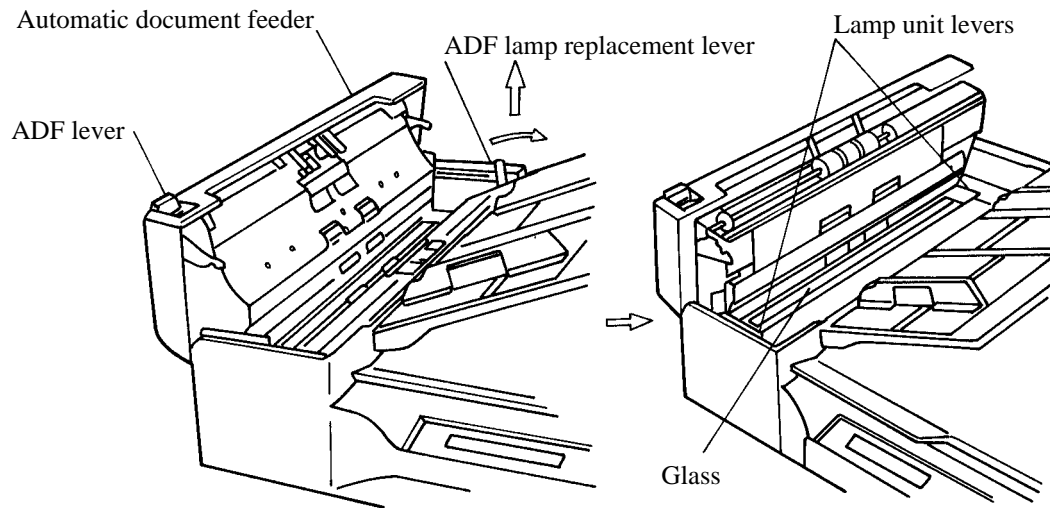

**Figure 5.4 Lamp unit removal 1**

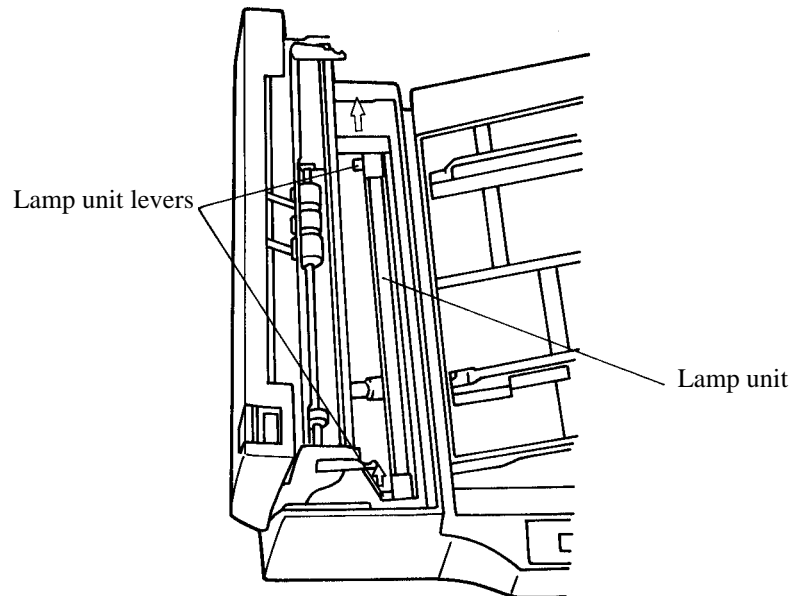
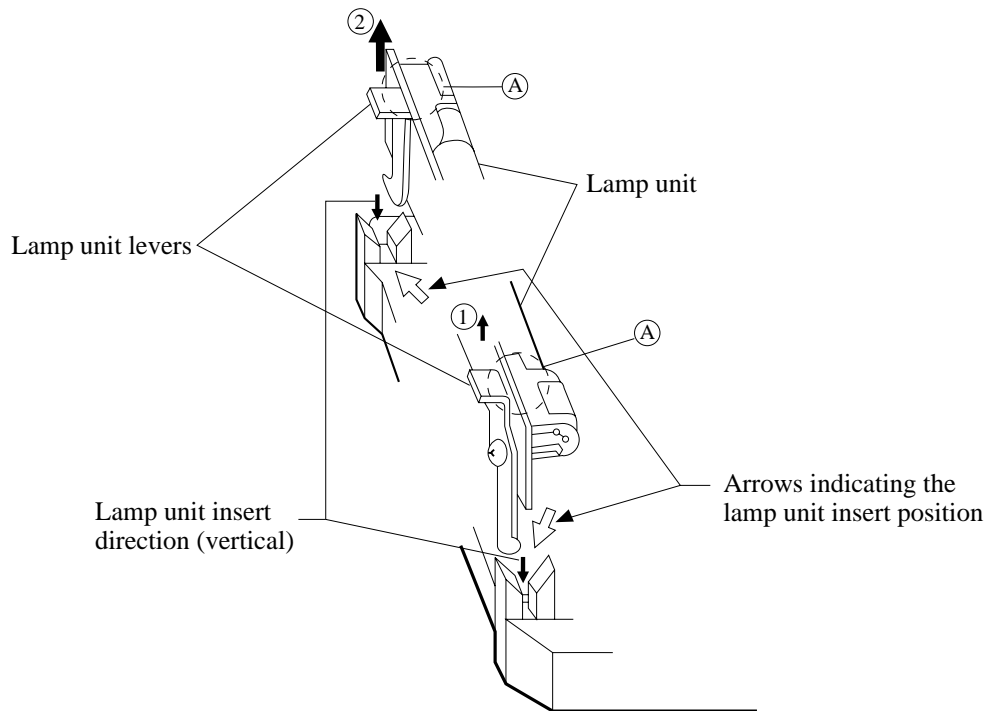

**Figure 5.5 Lamp unit removal 2**

- Then carefully pull it up with the front and (① in Figure 5.6) first and the back and (② in Figure 5.6) next. If the levers are pulled up carelessly, the lamp may be broken.



Hot: The lamp surface may be very hot. Be careful not to touch the lamp surface.

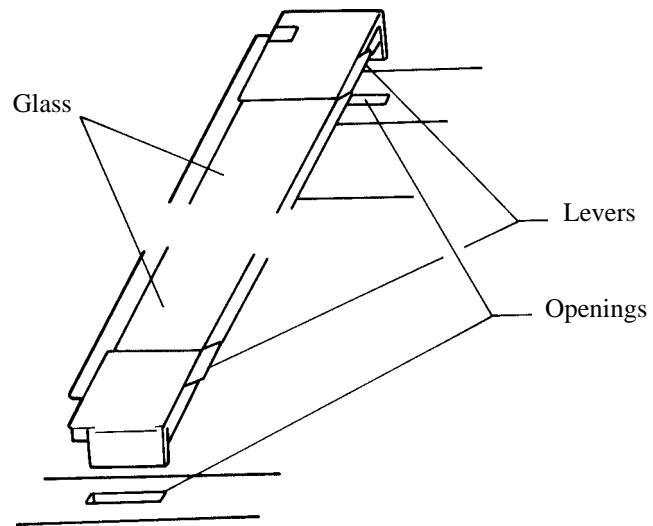

**Figure 5.6 Lamp unit replacement**

- Obtain a new lamp unit.
- Hold the new lamp unit with both hands. Insert it in the insertion slits with the back end first and the front and second by pressing points indicated with (A) in Figure 5.6.
- After completely inserting the lamp unit, hold the lamp unit levers with both hands and insert both ends of the glass into the openings.

**IMPORTANT**

If the lamp unit is not inserted completely, the carrier may not operate. The ADF may not close if the both ends of the glass are not inserted in the openings correctly.

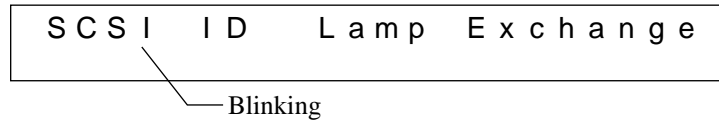

**Figure 5.7** Inserting the glass

- Close the ADF to lock ADF lever.

## 5.5 SCSI Address Setting (M3097G)

Press the power switch while pressing the mode 1 button. The liquid crystal display unit displays the following screen.



Press the mode 2 button to shift the blinking position. To set a device address, press the mode 1 button while "SCSI ID" is blinking.



The liquid crystal display screen displays this screen. A value from 0 to 7 is displayed in turn each time the mode 1 button is pressed. Press the mode 2 button to store the value when an appropriate value is displayed.

Confirm that the following screen is displayed, and turn off the power.

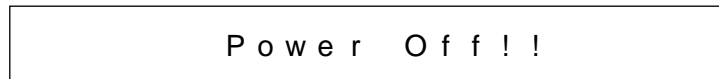

## 5.6 Replacing the pad

- (1) Pull up the ADF open and close lever to open the ADF.
- (2) Remove the four screws shown in Figure 5.8 to remove the two pads.
- (3) Install the pad by reversing the removal procedure.

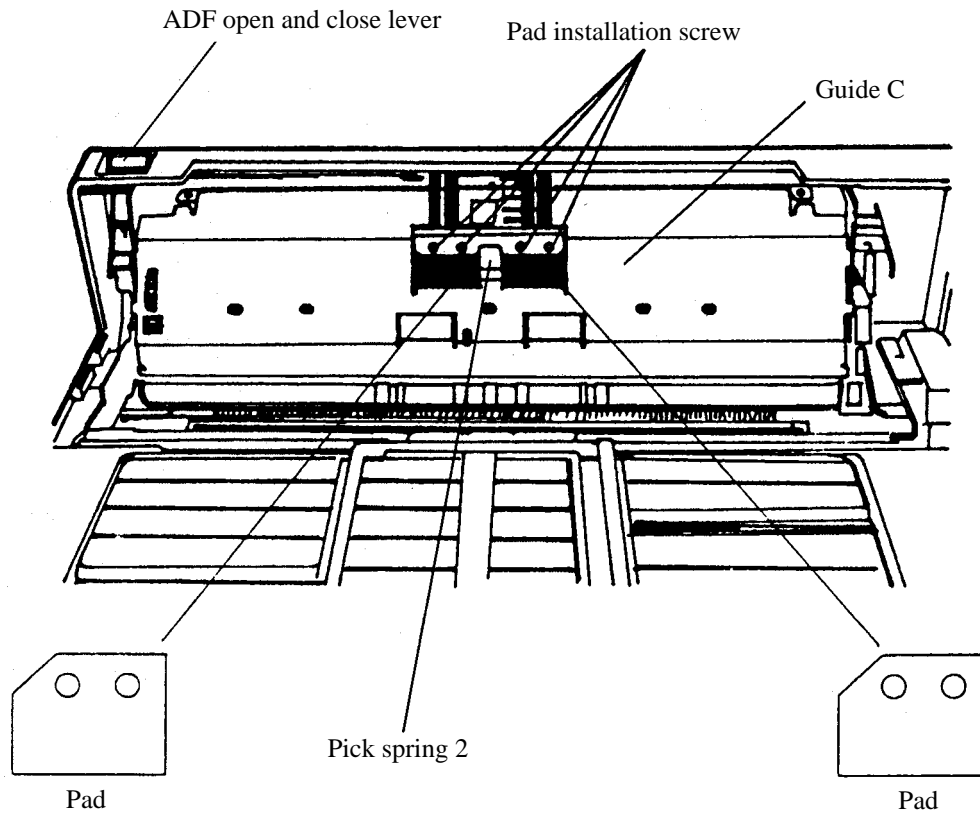

**Figure 5.8 Removing the pad**

### **NOTICE**

Attach the pad so that the corner cut is top left. Attach the pad so that the edges do not go under the pick spring 2 or over guide C.

## 5.7 Document counter display and reset

The Document counter is useful for users to check the total number of scanned documents before cleaning or pad replacement. This counter can be displayed or reset using the following procedures.

- (1) Turn on the power while holding down the Mode 1 button. The scanner displays the following message.

For M3097E :

Please wait Lamp is cooling off
------------------------------------

For M3097G :

SCSI ID Lamp Exchange
-----------------------

Continue pressing the Mode 1 button until the scanner displays the screen A.

Screen A

<<SETUP MODE>> PAPER COUNT RESET
-------------------------------------

- (2) Press the Mode 2 button. The scanner displays Screen B. When the Mode 2 button is pressed from now on the scanner alternately displays Screen A or B.

Screen B

RESET	COUNT
OFF	XXXXXXXX

blinking

Document counter

Note This counter is not accurate enough to use double feed check.

- (3) In order to reset the document counter, hold down the Mode 1 button for more than one second at Screen B. When the scanner displays Screen C, the Document counter has been reset.

Screen B

RESET	COUNT
ON	0

Press the Mode 2 button to go back to Screen A.

**This page is intentionally left blank.**

## CHAPTER 6 TROUBLESHOOTING

If a problem occurs, use Table 6.1 to resolve the problem.

**Table 6.1 Check items**

Problem	Possible cause	Response
No power	The power switch was not turned on.	Press the power switch.
	The power cable was not connected correctly.	Connect the power cable correctly.
	_____	Turn off the power once and make an attempt to turn on the power again. If the power is not turned on, contact your Fujitsu service representative.
Read operation does not start.	The ready indicator was not on (in the manual mode for M3097E).	If the ready indicator is on, press the start button.
	The documents were not placed on the ADF correctly.	Insert the first a few pages into the slot.
	The ADF was not closed completely.	Make sure that the ADF is closed completely.
	The interface cables were not connected correctly.	Connect the interface cables correctly.
Pictures and photographs are not read correctly.	Halftone processing was not selected.	Select a halftone mode from the host system, or use the halftone button if M3097E is used.
	The document bed, document holding pad, or inside ADF is dirty.	Clean the dirty parts as explained in Section 5.3, "Cleaning."
Characters and lines are not read correctly.	Simple binarization was not done.	Select a binarization mode from the host computer, or use the halftone button if M3097E is used.
	The document bed, document holding pad, or the inside of the ADF is dirty.	Clean the dirty parts as explained in Section 5.3, "Cleaning."
Image is distorted or unclear.	The document was moved during the read operation.	Keep the document cover closed during reading so that the document will not be moved.
	The document was not in contact with the glass.	Adjust the document so that it is in contact with the glass.

**Table 6.1 Check items (continued)**

Problem	Possible cause	Response
The lamp does not light (ready) while the power indicator blinks.	The interface cables were not connected correctly.	Connect the interface cables correctly.
	The terminator was not connected.	Connect the terminator.
The check indicator is on.	The carrier fixing bracket was not removed.	Remove the carrier fixing bracket as explained in Section 3.2, "Removing the Carrier Fixing Bracket."
	_____	Turn the power off then on again. If the check indicator turns on again, contact the sales person in charge or a Fujitsu service representative.
"Please clean-up!!" is displayed on the operator panel during the read operation.	The mirror is dirty.	Clean the mirror as explained in Section 5.3.4.
"Please clean Pick-roller" is displayed on the operator panel during the read operation in the automatic document feeder.	The pick roller is dirty.	When the power is turned off, the message is cleared. Even if the message is displayed, the read operation can be continued. Clean the pick roller after the read operation. (See Section 5.3.2.)
	The unallowable document was read in the automatic document feeder. (See Section 4.3.)	If a document not meeting the scanner specifications is read in the automatic document feeder, the document is not fed smoothly and an error message may be displayed. Read the document in the flat bed station.
Paper double feed	Pad is dirty.	Clean the Pad. (See Section 5.3.2)
Miss pick	Pick rollers are dirty.	Clean the Pick rollers. (See Section 5.3.2)
Paper jam	Some foreign particles are in ADF	Clean the ADF (See Section 5.3.2) or remove any foreign particles.

# APPENDIX

## A.1 Installation Specifications

**Table A.1 Installation specifications**

Item		Specification		
External dimensions (mm)		Width	Depth	Height
		696	497	173
Weight (kg)		25		
Input power	Voltage	100 to 120 VAC, 220 to 240 VAC		
	Number of phases	Single-phase		
	Frequency	50/60 Hz		
Power		150 VA		
Temperature and humidity allowed ranges		Operation		Idle
		Temperature	5 to 35°C	-20 to 60°C
		Humidity	20 to 80%	8 to 95%

## A.2 External Dimensions

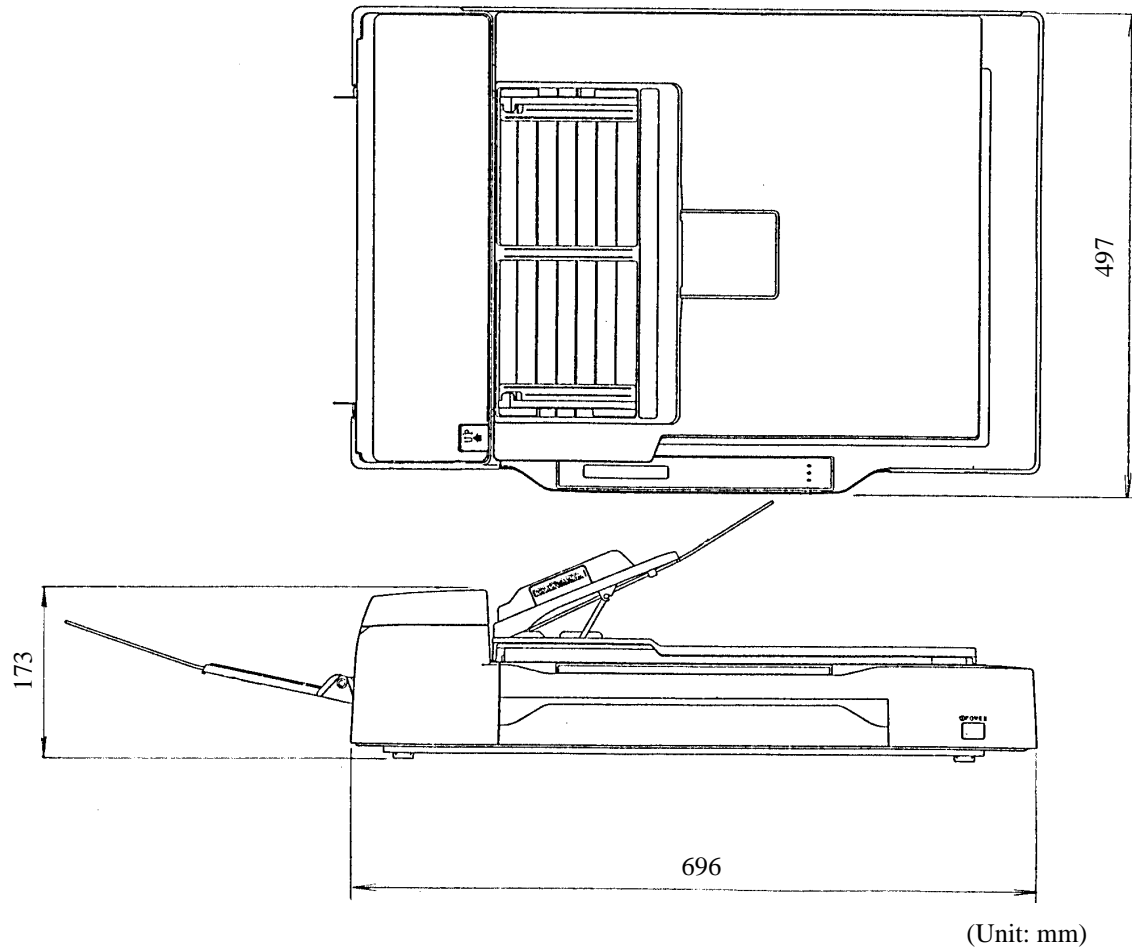

Figure A.1 External dimensions



DECLARATION OF CONFORMITY  
according to EN 45014

We

Fujitsu Europe Limited

of

2 Longwalk Road, Stockly Park, Uxbridge, Middlesex UB11 1AB, U.K.

declares under our sole responsibility that the product including the  
options or accessories

Product Type: Image Scanner

Model Number: M3097E

to which this declaration relates is in conformity with the following  
standards:

European standards :  
a. EN 55022 1987, class B  
b. EN 50082-1 1992  
(IEC 801-2 1984/IEC 801-3 1984/IEC 801-4 1988)

By conformance with the standards referenced the product follows the  
provisions of the directives listed below :

- a. EC Council Directive 89/336/EEC of 3 May 1989
- b. EC Council Directive 92/31/EEC of 28 April 1992
- c. EC Council Directive 93/68/EEC of 22 July 1993

Place of Issue: United Kingdom

Date of Issue: 27th October, 1995

Authorized by: Masanobu Suzuki

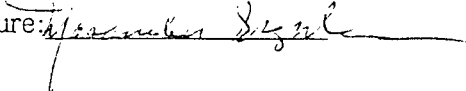
Signature: 

Title of Authority: Managing Director

Declaration Reference :

FUJITSU EUROPE LTD.  
2 Longwalk Road,  
Stockly Park,  
Uxbridge,  
Middlesex UB11 1AB,  
U.K.



DECLARATION OF CONFORMITY  
according to EN 45014

We

Fujitsu Europe Limited

of

2 Longwalk Road, Stockly Park, Uxbridge, Middlesex UB11 1AB, U.K.

declares under our sole responsibility that the product including the options or accessories

Product Type: Image Scanner

Model Number: M3097G

to which this declaration relates is in conformity with the following standards:

European standards :  
a. EN 55022 1987, class B  
b. EN 50082-1 1992  
(IEC 801-2 1984/IEC 801-3 1984/IEC 801-4 1988)

By conformance with the standards referenced the product follows the provisions of the directives listed below :

- a. EC Council Directive 89/336/EEC of 3 May 1989
- b. EC Council Directive 92/31/EEC of 28 April 1992
- c. EC Council Directive 93/68/EEC of 22 July 1993

Place of Issue: United Kingdom

Date of Issue: 27th October, 1995

Authorized by: Masanobu Suzuki

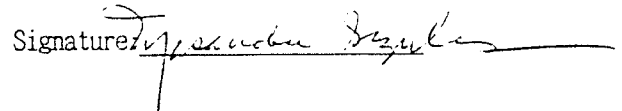
Signature 

Title of Authority: Managing Director

Declaration Reference :

FUJITSU EUROPE LTD.  
2 Longwalk Road,  
Stockly Park,  
Uxbridge,  
Middlesex UB11 1AB,  
U. K.

Comments concerning this manual can be directed to one of the following addresses:

FUJITSU LIMITED  
International Operations  
Marunouchi 1-6-1, Chiyoda-ku, Tokyo 100  
JAPAN  
TEL: (81-3) 3216-3211  
FAX: (81-3) 3213-7174  
TLX: J22833  
Cable: "FUJITSU LIMITED TOKYO"

FUJITSU COMPUTER PRODUCTS OF  
AMERICA, INC.  
2904 Orchard Parkway, San Jose, California  
95134-2022, U.S.A.  
TEL: 1-408-432-6333  
FAX: 1-408-432-3908

FUJITSU CANADA INC.  
2800 Matheson Blvd. East, Mississauga, Ontario  
4X5, CANADA  
TEL: 1-905-602-5454  
FAX: 1-905-602-5457

FUJITSU EUROPE LTD.  
2, Longwalk Road, Stockley Park, Uxbridge,  
Middlesex UB11 1AB, UK  
TEL: 44-81-573-4444  
FAX: 44-81-573-2643  
TLX: 263871

FUJITSU DEUTSCHLAND GmbH  
Frankfurter Ring 211, 8000 Munchen 40, F.R.  
GERMANY  
TEL: 49-89-32378-0  
FAX: 49-89-32378-100

FUJITSU NORDIC AB  
Kung Hans Vag, S-191 76 Sollentuna, SWEDEN  
TEL: 46-8-626-6000  
FAX: 46-8-626-6711

FUJITSU ITALIA S.p.A.  
Via Melchiorre Gioia, No.8-20124 Milano, ITALY  
TEL: 39-2-63651  
FAX: 39-2-6572257

FUJITSU FRANCE S. A.  
Batiment Aristote, 17 rue Olof Palme-94006  
Creteil cedex, FRANCE  
TEL: 33-14-513-1616  
FAX: 33-14-399-0700

FUJITSU AUSTRALIA LIMITED  
475 Victoria Avenue, Chatswood, N.S.W. 2067,  
AUSTRALIA  
TEL: 61-2-410-4555  
FAX: 61-2-411-8603

FUJITSU HONG KONG LIMITED  
Room 2521, Sun Hung Kai Centre, 30 Harbour  
Road Wanchal, HONG KONG  
TEL: 852-827-5780  
FAX: 852-827-4724



**FUJITSU**